

**DEPARTMENT OF COMPUTER SCIENCE AND  
ENGINEERING**

**DIGITAL NOTES  
ON  
COMPUTER ORGANIZATION  
R22A0508**

**B. TECH II YEAR–II SEM  
(R22) REGULATION  
(2023-24)**



**Prepared by  
P Honey Diana, Asst.Professor**

**MALLA REDDY COLLEGE OF ENGINEERING & TECHNOLOGY  
(Autonomous Institution–UGC, Govt.of India)**

Recognized under 2(f) and 12(B) of UGC ACT 1956  
(Affiliated to JNTUH, Hyderabad, Approved by AICTE - Accredited by NBA & NAAC - 'A' Grade -  
ISO 9001:2015 Certified)

Maisammaguda, Dhulapally (Post Via. Hakimpet), Secunderabad–500100, Telangana State, India

---

# MALLA REDDY COLLEGE OF ENGINEERING AND TECHNOLOGY

II Year B.Tech. CSE- II Sem

L/T/P/C  
3/-/-3

## (R22A0508) COMPUTER ORGANIZATION

### COURSE OBJECTIVES:

To expose the students to the following:

1. How Computer Systems work & the basic principles
2. Instruction Level Architecture and Instruction Execution
3. The current state of art in memory system design
4. How I/O devices are accessed and its principles.
5. To provide the knowledge on Instruction Level Parallelism

### UNIT I

**Basic Functional units of Computers:** Functional units, basic Operational concepts, Bus structures. Software, Performance, Multiprocessors, Multicomputer. **Data Representation:** Signed number representation, fixed and floating point Representations.

**Computer Arithmetic:** Addition and subtraction, multiplication Algorithms, Division Algorithms. Error detection and correction codes.

### UNIT II

**Register Transfer Language and Micro Operations:** RTL- Registers, Register transfers, Bus and memory transfers. Micro operations: Arithmetic, Logic, and Shift micro operations, Arithmetic logic shift unit.

**Basic Computer Organization and Design:** Computer Registers, Computer instructions, Instruction cycle. Instruction codes, Timing and Control, Types of Instructions: Memory Reference Instructions, Input – Output and Interrupt.

### UNIT III

**Central Processing Unit organization:** General Register Organization, Stack organization, Instruction formats, Addressing modes, Data Transfer and Manipulation, Program Control, CISC and RISC processors

**Control unit design:** Design approaches, Control memory, Address sequencing, micro program example, design of CU. Micro Programmed Control.

### UNIT IV

**Memory Organization:** Semiconductor Memory Technologies, Memory hierarchy, Interleaving, Main Memory-RAM and ROM chips, Address map, Associative memory-Hardware organization. Match logic. Cache memory-size vs. block size, Mapping functions-Associate, Direct, Set Associative mapping. Replacement algorithms, write policies. Auxiliary memory- Magnetic tapes etc

---

---

## **UNIT V**

**Input –Output Organization:** Peripheral devices, Input-output subsystems, I/O device interface, I/O Processor, I/O transfers–Program controlled, Interrupt driven, and DMA, interrupts and exceptions. I/O device interfaces – SCII, USB

**Pipelining and Vector Processing:** Basic concepts, Instruction level Parallelism Throughput and Speedup, Pipeline hazards.

### **TEXT BOOKS:**

1. Computer Organization – Carl Hamacher, Zvonks Vranesic, SafeaZaky, Vth Edition, McGraw Hill.
2. Computer Systems Architecture – M.Moris Mano, IIIrd Edition, Pearson/PHI

### **REFERENCE BOOKS:**

1. “Computer Architecture and Organization”, 3rd Edition by John P. Hayes, WCB/McGraw-Hill
2. “Computer Organization and Architecture: Designing for Performance”, 10th Edition by
  - i. William Stallings, Pearson Education.
3. “Computer System Design and Architecture”, 2nd Edition by Vincent P. Heuring and Harry
  - ii. F. Jordan, Pearson Education.

### **COURSE OUTCOMES:**

Upon completion of this course, students should be able to:

1. Student will learn the concepts of computer organization for several engineering applications.
  2. Student will develop the ability and confidence to use the fundamentals of computer organization as a tool in the engineering of digital systems.
  3. An ability to identify, formulate, and solve hardware and software computer engineering problems using sound computer engineering principle
  4. To impart the knowledge on micro programming
  5. Comprehend the concepts of advanced pipelining techniques
-

**INDEX**

<b>UNIT NO</b>	<b>TOPIC</b>	<b>PAGE NO</b>
<b>I</b>	Basic Functional units of Computers	<b>1-10</b>
	Data Representation	<b>11-13</b>
<b>II</b>	Register Transfer Language and Micro Operations	<b>14-27</b>
	Basic Computer Organization and Design	<b>28-42</b>
<b>III</b>	Central Processing Unit organization	<b>43-50</b>
	Control unit design	<b>51-57</b>
<b>IV</b>	Memory Organization	<b>58-65</b>
<b>V</b>	Input –Output Organization	<b>66-74</b>
	Pipelining and Vector Processing	<b>74-78</b>

---

**UNIT I****Syllabus:**

Basic Functional units of Computers: functional units, basic Operational concepts, Bus structures. Software, Performance, Multiprocessors, Multicomputer.

Data Representation: Signed number representation, fixed and floating point Representations.

Computer Arithmetic: Addition and subtraction, multiplication Algorithms, Division Algorithms.

Error detection and correction codes.

---

**Basic Structure of Computers**

Computer Architecture in general covers three aspects of computer design namely: Computer Hardware, Instruction set Architecture and Computer Organization.

Computer hardware consists of electronic circuits, displays, magnetic and optical storage media and communication facilities.

Instruction set Architecture is programmer visible machine interface such as instruction set, registers, memory organization and exception handling. Two main approaches are mainly CISC (Complex Instruction Set Computer) and RISC (Reduced Instruction Set Computer)

Computer Organization includes the high level aspects of a design, such as memory system, the bus structure and the design of the internal CPU.

**Computer Types**

Computer is a fast electronic calculating machine which accepts digital input, processes it according to the internally stored instructions (Programs) and produces the result on the output device. The internal operation of the computer can be as depicted in the figure below:

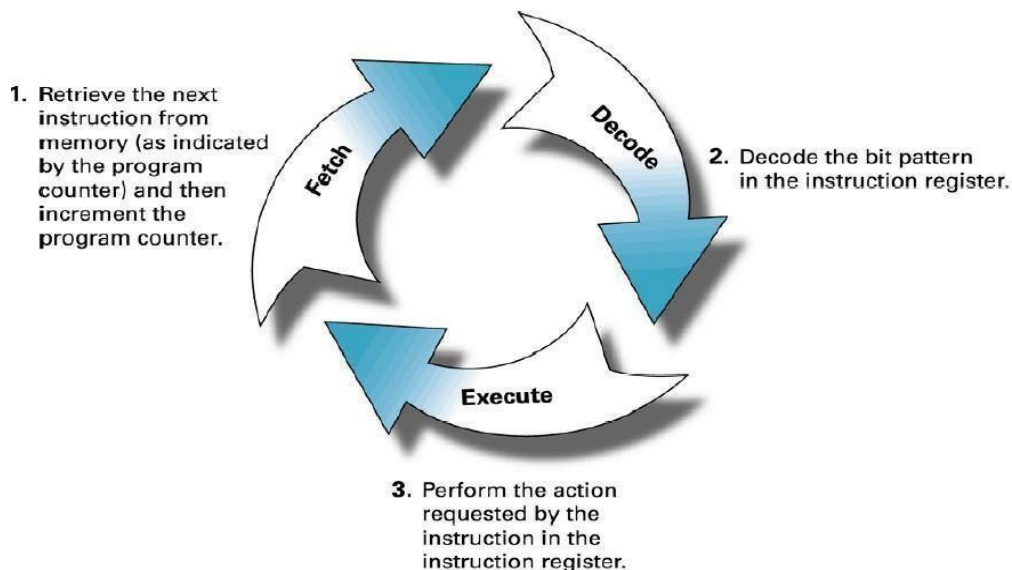

**Figure 1: Fetch, Decode and Execute steps in a Computer System**

The computers can be classified into various categories as given below:

- Micro Computer
- Laptop Computer
- Work Station
- Super Computer
- Main Frame
- Hand Held
- Multi core

**Micro Computer:** A personal computer; designed to meet the computer needs of an individual. Provides access to a wide variety of computing applications, such as word processing, photo editing, e-mail, and internet.

**Laptop Computer:** A portable, compact computer that can run on power supply or a battery unit. All components are integrated as one compact unit. It is generally more expensive than a comparable desktop. It is also called a Notebook.

**Work Station:** Powerful desktop computer designed for specialized tasks. Generally used for tasks that requires a lot of processing speed. Can also be an ordinary personal computer attached to a LAN (local area network).

**Super Computer:** A computer that is considered to be fastest in the world. Used to execute tasks that would take lot of time for other computers. For Ex: Modeling weather systems, genome sequence, etc (Refer site: <http://www.top500.org/>)

**Main Frame:** Large expensive computer capable of simultaneously processing data for hundreds or thousands of users. Used to store, manage, and process large amounts of data that need to be reliable, secure, and centralized.

**Hand Held:** It is also called a PDA (Personal Digital Assistant). A computer that fits into a pocket, runs on batteries, and is used while holding the unit in your hand. Typically used as an appointment book, address book, calculator and notepad.

**Multi Core:** Have Multiple Cores – parallel computing platforms. Many Cores or computing elements in a single chip. Typical Examples: Sony Play station, Core 2 Duo, i3, i7 etc.

## GENERATION OF COMPUTERS

Development of technologies used to fabricate the processors, memories and I/O units of the computers has been divided into various generations as given below:

- First generation
- Second generation
- Third generation
- Fourth generation
- Beyond the fourth generation

**First generation:**

1946 to 1955: Computers of this generation used Vacuum Tubes. The computers were built using stored program concept. Ex: ENIAC, EDSAC, IBM 701.

Computers of this age typically used about ten thousand vacuum tubes. They were bulky in size had slow operating speed, short life time and limited programming facilities.

**Second generation:**

1955 to 1965: Computers of this generation used the germanium transistors as the active switching electronic device. Ex: IBM 7000, B5000, IBM 1401. Comparatively smaller in size About ten times faster operating speed as compared to first generation vacuum tube based computers. Consumed less power, had fairly good reliability. Availability of large memory was an added advantage.

**Third generation:**

1965 to 1975: The computers of this generation used the Integrated Circuits as the active electronic components. Ex: IBM system 360, PDP minicomputer etc. They were still smaller in size. They had powerful CPUs with the capacity of executing 1 million instructions per second (MIPS). Used to consume very less power consumption.

**Fourth generation:**

1976 to 1990: The computers of this generation used the LSI chips like microprocessor as their active electronic element. HCL horizon III, and WIPRO'S Uniplus+ HCL's Busybee PC etc.

They used high speed microprocessor as CPU. They were more user friendly and highly reliable systems. They had large storage capacity disk memories.

**Beyond Fourth Generation:**

1990 onwards: Specialized and dedicated VLSI chips are used to control specific functions of these computers. Modern Desktop PC's, Laptops or Notebook Computers.

Each generation of computers represents a significant advancement in computing technology, resulting in faster processing speeds, greater storage capacity, and improved functionality. The development of computer generations has been driven by advances in technology and changes in user needs and demands

A computer is an electronic device that manipulates information or data. It can store , retrieve, and process.

Nowadays, a computer can be used to type documents, send an email, play games, and browse the Web. It can also be used to edit or create spreadsheets, presentations, and even videos. But the evolution of this complex system started around 1940 with the First Generation of computers and evolving ever since.

The evolution of computers started around the 16th century. The evolution of the computer is the process of which transformation of the oldest vacuum tube-based system to the current model system of today's computers. Long ago, the early primitive people were trailblazers in the use of counting tools, making use of objects like sticks, stones, and bones for their counting needs. The computer we see today has faced many changes, for the betterment via history of computers. It has continuously improved itself in terms of speed, accuracy, size, and price to urge the form of the computer we have today. Here we have discussed the 5 generations of computers and their characteristics... Read more at: <https://www.careerpower.in/school/computer/generation-of-computer>



## Functional Unit

A computer in its simplest form comprises five functional units namely input unit, output unit, memory unit, arithmetic & logic unit and control unit. Figure 2 depicts the functional units of a computer system.

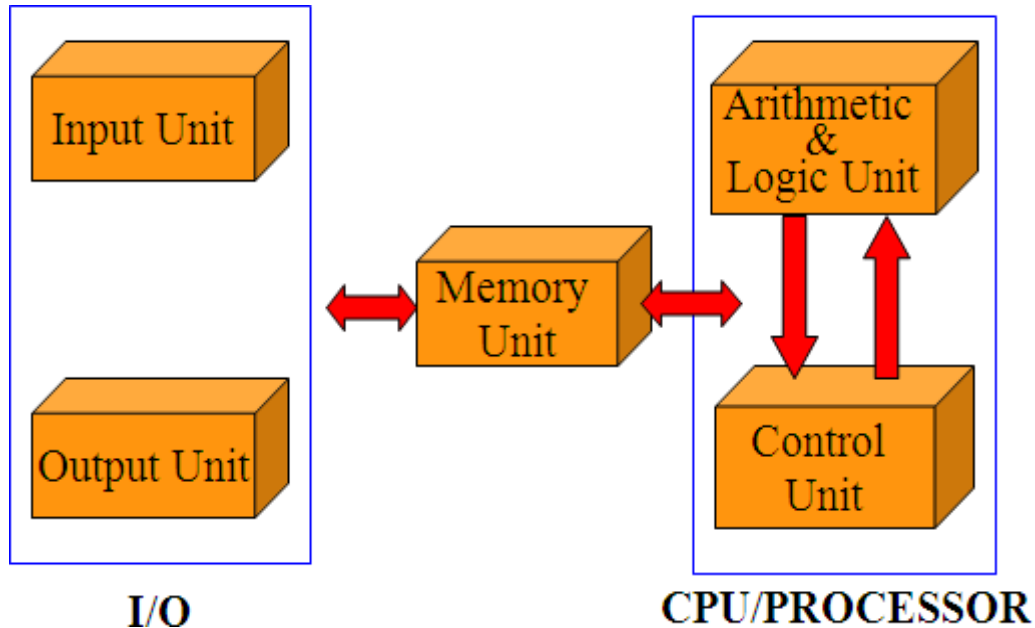

**Figure 2: Basic functional units of a computer**

Let us discuss about each of them in brief:

1. **Input Unit:** Computer accepts encoded information through input unit. The standard input device is a keyboard. Whenever a key is pressed, keyboard controller sends the code to CPU/Memory.

Examples include Mouse, Joystick, Tracker ball, Light pen, Digitizer, Scanner etc.

2. **Memory Unit:** Memory unit stores the program instructions (Code), data and results of computations etc. Memory unit is classified as:

- Primary /Main Memory
- Secondary /Auxiliary Memory

**Primary memory** is a semiconductor memory that provides access at high speed. Run time program instructions and operands are stored in the main memory. Main memory is classified again as ROM and RAM. ROM holds system programs and firmware routines such as BIOS, POST, I/O Drivers that are essential to manage the hardware of a computer. RAM is termed as Read/Write memory or user memory that holds run time program instruction and data. While primary storage is essential, it is volatile in nature and expensive. Additional requirement of memory could be supplied as auxiliary memory at cheaper cost. **Secondary memories** are non volatile in nature.

3. **Arithmetic and logic unit:** ALU consist of necessary logic circuits like adder, comparator etc., to perform operations of addition, multiplication, comparison of two numbers etc.
4. **Output Unit:** Computer after computation returns the computed results, error messages, etc. via output unit. The standard output device is a video monitor, LCD/TFT monitor. Other output devices are printers, plotters etc.
5. **Control Unit:** Control unit co-ordinates activities of all units by issuing control signals. Control signals issued by control unit govern the data transfers and then appropriate operations take place. Control unit interprets or decides the operation/action to be performed.

The operations of a computer can be summarized as follows:

1. A set of instructions called a program reside in the main memory of computer.
2. The CPU fetches those instructions sequentially one-by-one from the main memory, decodes them and performs the specified operation on associated data operands in ALU.
3. Processed data and results will be displayed on an output unit.
4. All activities pertaining to processing and data movement inside the computer machine are governed by control unit.

## Basic Operational Concepts

An Instruction consists of two parts, an Operation code and operand/s as shown below:

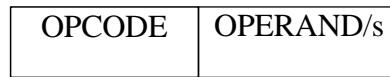

Let us see a typical instruction  
ADD LOCA, R0

This instruction is an addition operation. The following are the steps to execute the instruction:

- Step 1: Fetch the instruction from main memory into the processor
- Step 2: Fetch the operand at location LOCA from main memory into the processor
- Step 3: Add the memory operand (i.e. fetched contents of LOCA) to the contents of register R0
- Step 4: Store the result (sum) in R0.

The same instruction can be realized using two instructions as

```
Load  LOCA,
R1  Add  R1,
R0
```

The steps to execute the instructions can be enumerated as below:

- Step 1: Fetch the instruction from main memory into the processor
- Step 2: Fetch the operand at location LOCA from main memory into the processor Register R1
- Step 3: Add the content of Register R1 and the contents of register R0
- Step 4: Store the result (sum) in R0.

Figure 3 below shows how the memory and the processor are connected. As shown in the diagram, in addition to the ALU and the control circuitry, the processor contains a number of registers used for several different purposes. The instruction register holds the instruction that is currently being executed. The program counter keeps track of the execution of the program. It contains the memory address of the next instruction to be fetched and executed. There are  $n$  general purpose registers  $R_0$  to  $R_{n-1}$  which can be used by the programmers during writing programs.

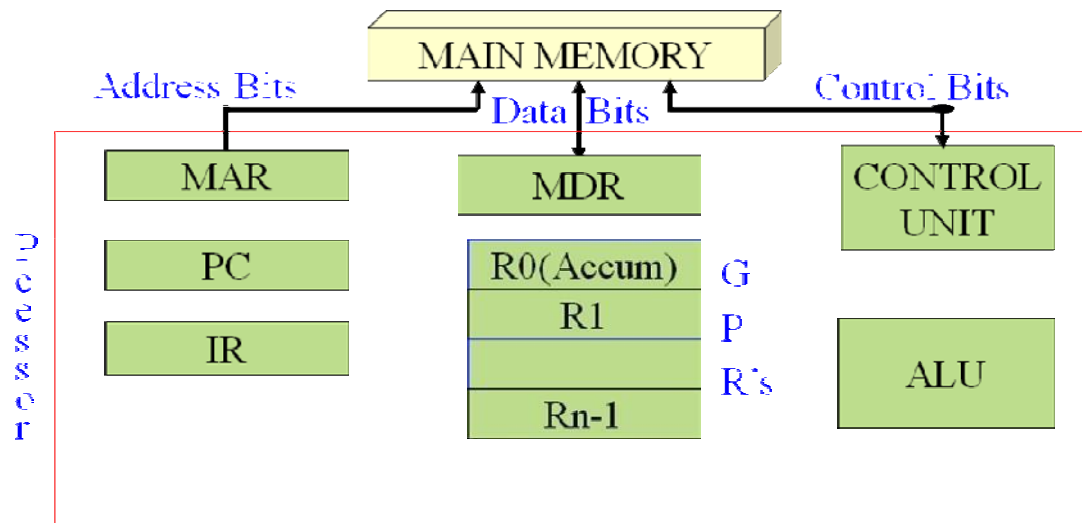

**Figure 3: Connections between the processor and the memory**

The interaction between the processor and the memory and the direction of flow of information is as shown in the diagram below:

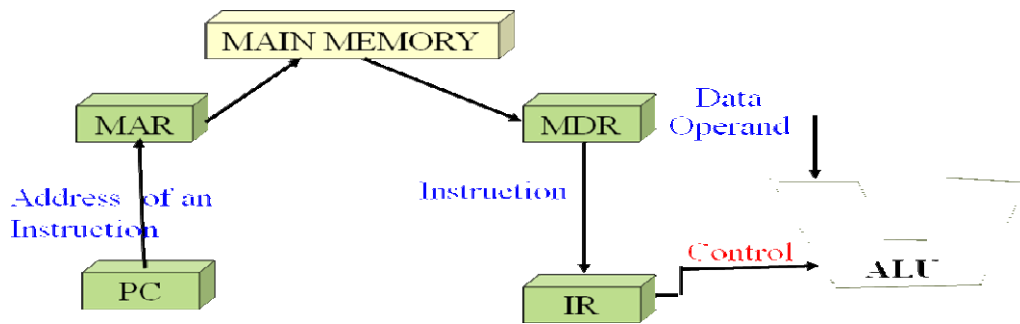

**Figure 4: Interaction between the memory and the ALU**

## BUS STRUCTURES

Group of lines that serve as connecting path for several devices is called a bus (one bit per line). Individual parts must communicate over a communication line or path for exchanging data, address and control information as shown in the diagram below. Printer example – processor to printer. A common approach is to use the concept of buffer registers to hold the content during the transfer.

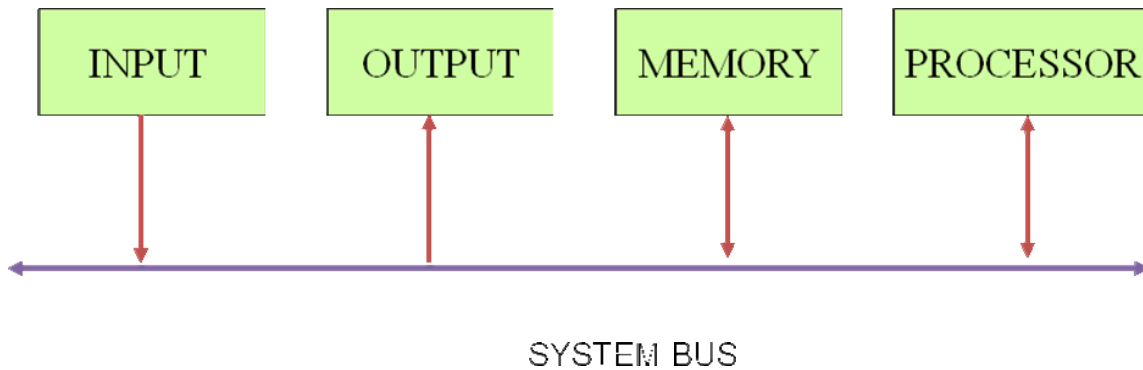

**Figure 5: Single bus structure**

## SOFTWARE

If a user wants to enter and run an application program, he/she needs a System Software. System Software is a collection of programs that are executed as needed to perform functions such as:

- Receiving and interpreting user commands
- Entering and editing application programs and storing them as files in secondary storage devices
- Running standard application programs such as word processors, spread sheets, games etc...

Operating system - is key system software component which helps the user to exploit the below underlying hardware with the programs.

## USER PROGRAM and OS ROUTINE INTERACTION

Let's assume computer with 1 processor, 1 disk and 1 printer and application program is in machine code on disk. The various tasks are performed in a coordinated fashion, which is called multitasking.  $t_0, t_1 \dots t_5$  are the instances of time and the interaction during various instances as given below:

$t_0$ : the OS loads the program from the disk to memory  
 $t_1$ : program executes  
 $t_2$ : program accesses disk  
 $t_3$ : program executes some more  
 $t_4$ : program accesses printer  
 $t_5$ : program terminates

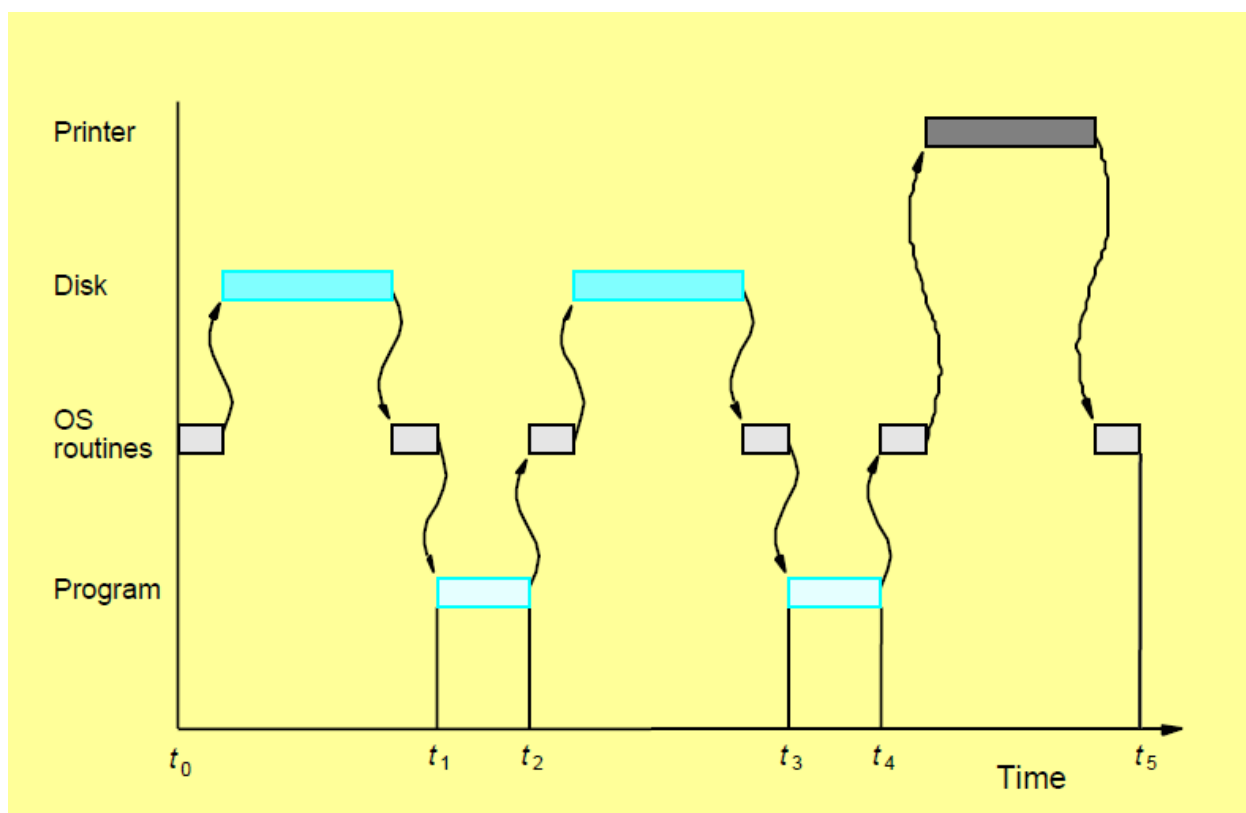

**Figure 6 :User program and OS routine sharing of the processor**

## PERFORMANCE

The most important measure of the performance of a computer is how quickly it can execute programs. The speed with which a computer executes program is affected by the design of its hardware. For best performance, it is necessary to design the compiles, the machine instruction set, and the hardware in a coordinated way.

The total time required to execute the program is elapsed time is a measure of the performance of the entire computer system. It is affected by the speed of the processor, the disk and the printer. The time needed to execute a instruction is called the processor time.

Just as the elapsed time for the execution of a program depends on all units in a computer system, the processor time depends on the hardware involved in the execution of individual machine instructions. This hardware comprises the processor and the memory which are usually connected by the bus.

The pertinent parts of the fig. c is repeated in fig. d which includes the cache memory as part of the processor unit.

Let us examine the flow of program instructions and data between the memory and the processor. At the start of execution, all program instructions and the required data are stored in the main memory. As the execution proceeds, instructions are fetched one by one over the bus into the processor, and a copy is placed in the cache later if the same instruction or data item is needed a second time, it is read directly from the cache. The processor and relatively small cache memory can be fabricated on a single IC chip. The internal speed of performing the basic steps of instruction processing on chip is very high and is considerably faster than the speed at which the instruction and data can be fetched from the main memory. A program will be executed faster if the movement of instructions and data between the main memory and the processor is minimized, which is achieved by using the cache.

For example:- Suppose a number of instructions are executed repeatedly over a short period of time as happens in a program loop. If these instructions are available in the cache, they can be fetched quickly during the period of repeated use. The same applies to the data that are used repeatedly.

**Processor clock:**

Processor circuits are controlled by a timing signal called clock. The clock designer the regular time intervals called clock cycles. To execute a machine instruction the processor divides the action to be performed into a sequence of basic steps that each step can be completed in one clock cycle. The length P of one clock cycle is an important parameter that affects the processor performance.

Processor used in today's personal computer and work station have a clock rates that range from a few hundred million to over a billion cycles per second.

**Basic performance equation:**

We now focus our attention on the processor time component of the total elapsed time. Let 'T' be the processor time required to execute a program that has been prepared in some high-level language. The compiler generates a machine language object program that corresponds to the source program. Assume that complete execution of the program requires the execution of N machine cycle language instructions. The number N is the actual number of instruction execution and is not necessarily equal to the number of machine cycle instructions in the object program. Some instruction may be executed more than once, which in the case for instructions inside a program loop others may not be executed all, depending on the input data used.

Suppose that the average number of basic steps needed to execute one machine cycle instruction is S, where each basic step is completed in one clock cycle. If clock rate is 'R' cycles per second, the program execution time is given by

$$T=N*S/R$$

this is often referred to as the basic performance equation.

We must emphasize that N, S & R are not independent parameters changing one may affect another. Introducing a new feature in the design of a processor will lead to improved performance only if the overall result is to reduce the value of T.

**Performance measurements:**

It is very important to be able to access the performance of a computer, comp designers use performance estimates to evaluate the effectiveness of new features.

The previous argument suggests that the performance of a computer is given by the execution time T, for the program of interest.

Inspite of the performance equation being so simple, the evaluation of 'T' is highly complex. Moreover the parameters like the clock speed and various architectural features are not reliable indicators of the expected performance.

Hence measurement of computer performance using bench mark programs is done to make comparisons possible, standardized programs must be used.

The performance measure is the time taken by the computer to execute a given bench mark. Initially some attempts were made to create artificial programs that could be used

as bench mark programs. But synthetic programs do not properly predict the performance obtained when real application programs are run.

A non profit organization called SPEC- system performance evaluation corporation selects and publishes bench marks.

The program selected range from game playing, compiler, and data base applications to numerically intensive programs in astrophysics and quantum chemistry. In each case, the program is compiled under test, and the running time on a real computer is measured. The same program is also compiled and run on one computer selected as reference.

The 'SPEC' rating is computed as follows.

$$\text{SPEC rating} = \frac{\text{Running time on the reference computer}}{\text{Running time on the computer under test}}$$

If the SPEC rating = 50

### **Multiprocessor & microprocessors:**

Large computers that contain a number of processor units are called multiprocessor system. These systems either execute a number of different application tasks in parallel or execute subtasks of a single large task in parallel. All processors usually have access to all memory locations in such system & hence they are called shared memory multiprocessor systems. The high performance of these systems comes with much increased complexity and cost. In contrast to multiprocessor systems, it is also possible to use an interconnected group of complete computers to achieve high total computational power. These computers normally have access to their own memory units when the tasks they are executing need to communicate data they do so by exchanging messages over a communication network. This properly distinguishes them from shared memory multiprocessors, leading to name message-passing multi computer.

### **Data Representation:**

Information that a Computer is dealing with

Data

Numeric Data

Numbers( Integer, real)

Non-numeric Data

Letters, Symbols

Relationship between data elements

Data Structures

Linear Lists, Trees, Rings, etc

Program(Instruction)



## Numeric Data Representation

Fixed	Decimal	Binary	Octal	Hexadecimal	Point
	00	0000	00	0	
	01	0001	01	1	
	02	0010	02	2	
	03	0011	03	3	
	04	0100	04	4	
	05	0101	05	5	
	06	0110	06	6	
	07	0111	07	7	
	08	1000	10	8	
	09	1001	11	9	
	10	1010	12	A	
	11	1011	13	B	
	12	1100	14	C	
	13	1101	15	D	
	14	1110	16	E	
	15	1111	17	F	

### Representation:

It's the representation for integers only where the decimal point is always fixed. i.e at the end of rightmost point. it can be again represented in two ways.

#### 1. Sign and Magnitude Representation

In this system, the most significant (leftmost) bit in the word as a sign bit. If the sign bit is 0, the number is positive; if the sign bit is 1, the number is negative.

The simplest form of representing sign bit is the sign magnitude representation.

One of the draw back for sign magnitude number is addition and subtraction need to consider both sign of the numbers and their relative magnitude.

Another drawback is there are two representation for 0(Zero) i.e +0 and -0.

#### 2. One's Complement (1's) Representation

In this representation negative values are obtained by complementing each bit of the corresponding positive number.

For example 1s complement of 0101 is 1010 . The process of forming the 1s complement of a given number is equivalent to subtracting that number from  $2^n - 1$  i.e from 1111 for 4 bit number.

Two's Complement (2's) Representation Forming the 2s complement of a number is done by subtracting that number from  $2^n$  . So 2s complement of a number is obtained by adding 1 to 1s complement of that number.

Ex: 2's complement of 0101 is  $1010 + 1 = 1011$

NB: In all systems, the leftmost bit is 0 for positive number and 1 for negative number.

### **Floating-point representation**

Floating-point numbers are so called as the decimal or binary point floats over the base depending on the exponent value.

It consists two components.

- Exponent
- Mantissa

Example: Avogadro's number can be written as  $6.02 \times 10^{23}$  in base 10. And the mantissa and exponent are 6.02 and 1023 respectively. But computer floating-point numbers are usually based on base two. So  $6.02 \times 10^{23}$  is approximately  $(1 \text{ and } 63/64) \times 2^{278}$  or  $1.111111$  (base two)  $\times 2^{1001110}$  (base two)

### **Error Detection Codes**

Parity System

Hamming Distance

CRC

Check sum

---

## UNIT 2

### Syllabus:

Register Transfer Language and Micro Operations: RTL- Registers, Register transfers, Bus and memory transfers. Micro operations: Arithmetic, Logic, and Shift micro operations, Arithmetic logic shift unit.

Basic Computer Organization and Design: Computer Registers, Computer instructions, Instruction cycle. Instruction codes, Timing and Control, Types of Instructions: Memory Reference Instructions, Input – Output and Interrupt, Complete Computer Description.

---

### Register Transfer Language And Micro Operations:

#### Register Transfer language:

- Digital systems are composed of modules that are constructed from digital components, such as registers, decoders, arithmetic elements, and control logic
- The modules are interconnected with common data and control paths to form a digital computer system
- The operations executed on data stored in registers are called microoperations
- A microoperation is an elementary operation performed on the information stored in one or more registers
- Examples are shift, count, clear, and load
- Some of the digital components from before are registers that implement microoperations
- The internal hardware organization of a digital computer is best defined by specifying
  - The set of registers it contains and their functions
  - The sequence of microoperations performed on the binary information stored
  - The control that initiates the sequence of microoperations
- Use symbols, rather than words, to specify the sequence of microoperations
- The symbolic notation used is called a register transfer language
- A programming language is a procedure for writing symbols to specify a given computational process
- Define symbols for various types of microoperations and describe associated hardware that can implement the microoperations

#### Register Transfer

- Designate computer registers by capital letters to denote its function
- The register that holds an address for the memory unit is called MAR
- The program counter register is called PC
- IR is the instruction register and R1 is a processor register
- The individual flip-flops in an n-bit register are numbered in sequence from 0 to n-1
- Refer to Figure 4.1 for the different representations of a register

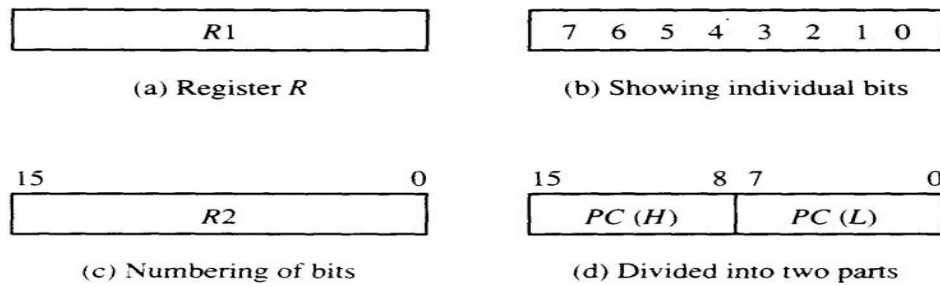
**Figure 4-1** Block diagram of register.

- Designate information transfer from one register to another by  $R2 \square R1$
- This statement implies that the hardware is available
  - The outputs of the source must have a path to the inputs of the destination
  - The destination register has a parallel load capability
- If the transfer is to occur only under a predetermined control condition, designate it by
  - If  $(P = 1)$  then  $(R2 \square R1)$
  - or
  - $P: R2 \square R1,$

where  $P$  is a control function that can be either 0 or 1

- Every statement written in register transfer notation implies the presence of the required hardware construction

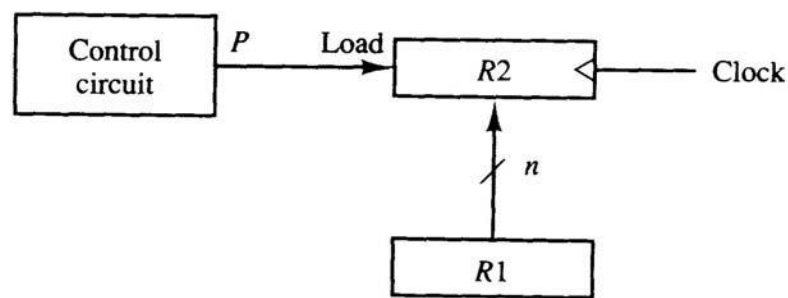
**Figure 4-2** Transfer from R1 to R2 when  $P = 1$ .

(a) Block diagram

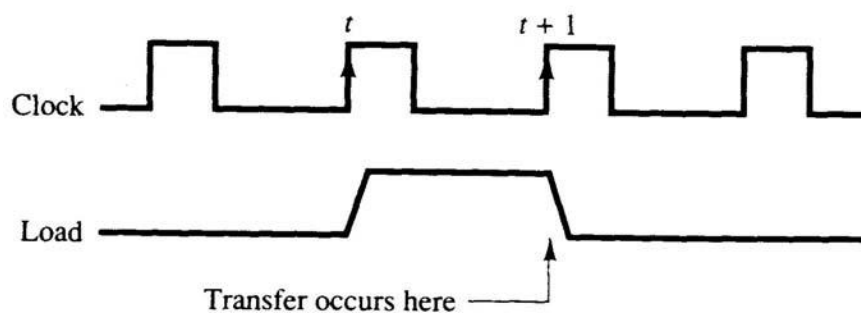

(b) Timing diagram

- It is assumed that all transfers occur during a clock edge transition
- All microoperations written on a single line are to be executed at the same time T:  
 $R2 \leftarrow R1, R1 \leftarrow R2$

**TABLE 4-1** Basic Symbols for Register Transfers

Symbol	Description	Examples
Letters (and numerals)	Denotes a register	$MAR, R2$
Parentheses ( )	Denotes a part of a register	$R2(0-7), R2(L)$
Arrow $\leftarrow$	Denotes transfer of information	$R2 \leftarrow R1$
Comma ,	Separates two microoperations	$R2 \leftarrow R1, R1 \leftarrow R2$

### Bus and Memory Transfers

- Rather than connecting wires between all registers, a common bus is used
- A bus structure consists of a set of common lines, one for each bit of a register
- Control signals determine which register is selected by the bus during each transfer
- Multiplexers can be used to construct a common bus

- Multiplexers select the source register whose binary information is then placed on the bus
- The select lines are connected to the selection inputs of the multiplexers and choose the bits of one register

Figure 4-3 Bus system for four registers.

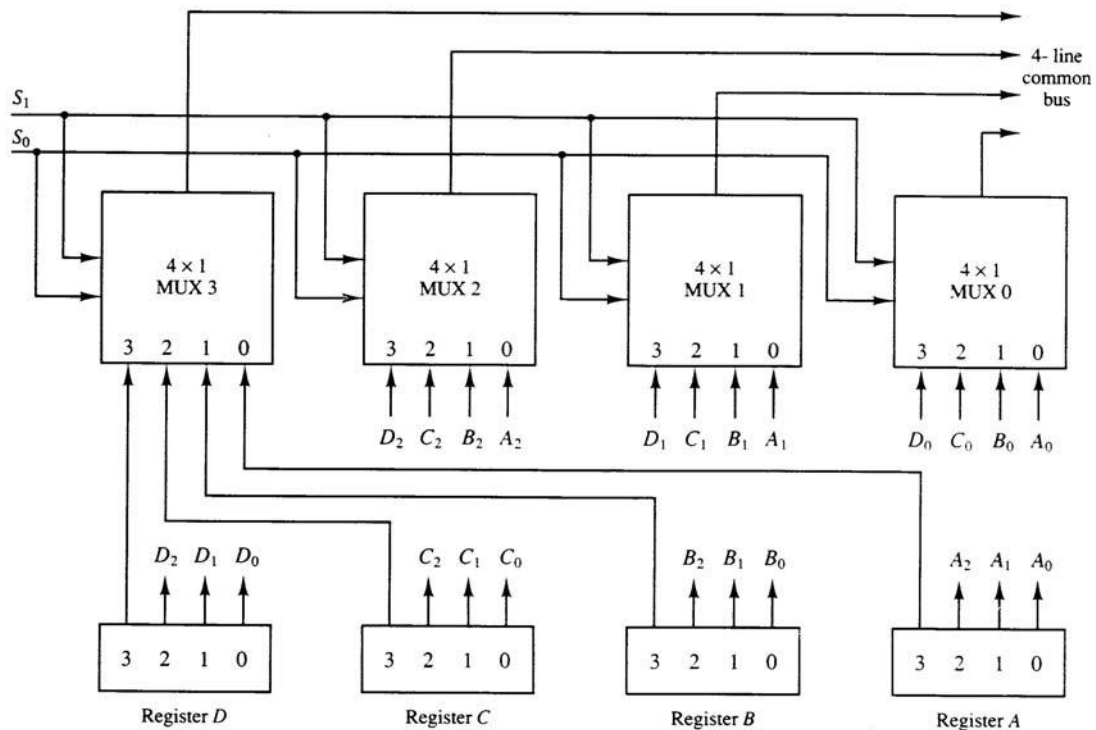

- In general, a bus system will multiplex  $k$  registers of  $n$  bits each to produce an  $n$ -line common bus
- This requires  $n$  multiplexers – one for each bit
- The size of each multiplexer must be  $k \times 1$
- The number of select lines required is  $\log k$
- To transfer information from the bus to a register, the bus lines are connected to the inputs of all destination registers and the corresponding load control line must be activated
- Rather than listing each step as  
 BUS  $\square$  C, R1  $\square$  BUS,  
 use R1  $\square$  C, since the bus is implied
- Instead of using multiplexers, three-state gates can be used to construct the bus system
- A three-state gate is a digital circuit that exhibits three states
- Two of the states are signals equivalent to logic 1 and 0
- The third state is a high-impedance state – this behaves like an open circuit, which means the output is disconnected and does not have a logic significance

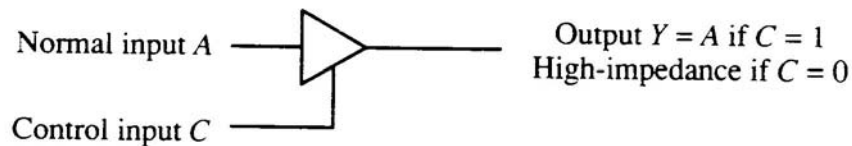
**Figure 4-4** Graphic symbols for three-state buffer.

- The three-state buffer gate has a normal input and a control input which determines the output state
- With control 1, the output equals the normal input
- With control 0, the gate goes to a high-impedance state
- This enables a large number of three-state gate outputs to be connected with wires to form a common bus line without endangering loading effects

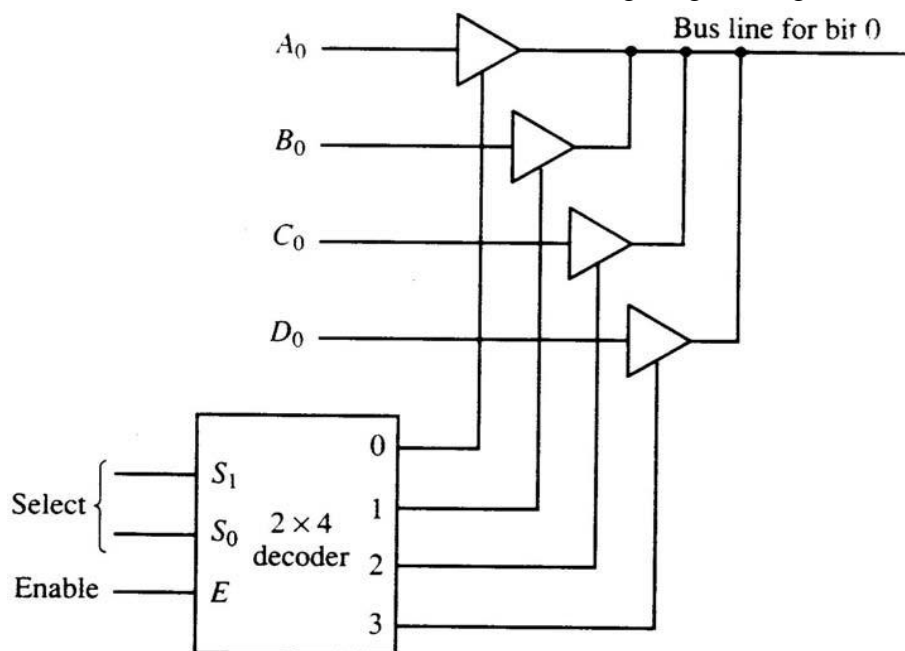
**Figure 4-5** Bus line with three state-buffers.

- Decoders are used to ensure that no more than one control input is active at any given time
- This circuit can replace the multiplexer in Figure 4.3
- To construct a common bus for four registers of n bits each using three-state buffers, we need n circuits with four buffers in each
- Only one decoder is necessary to select between the four registers
- Designate a memory word by the letter M
- It is necessary to specify the address of M when writing memory transfer operations
- Designate the address register by AR and the data register by DR
- The read operation can be stated as: Read: DR  $\square$  M[AR]
- The write operation can be stated as:  
 Write: M[AR]  $\square$  R1

## Arithmetic Microoperations

- There are four categories of the most common microoperations:
  - Register transfer: transfer binary information from one register to another
  - Arithmetic: perform arithmetic operations on numeric data stored in registers
  - Logic: perform bit manipulation operations on non-numeric data stored in registers
  - Shift: perform shift operations on data stored in registers
- The basic arithmetic microoperations are addition, subtraction, increment, decrement, and shift
- Example of addition:  $R3 \leftarrow R1 + R2$
- Subtraction is most often implemented through complementation and addition
- Example of subtraction:  $R3 \leftarrow R1 + \overline{R2} + 1$  (strikethrough denotes bar on top – 1's complement of R2)
- Adding 1 to the 1's complement produces the 2's complement
- Adding the contents of R1 to the 2's complement of R2 is equivalent to subtracting

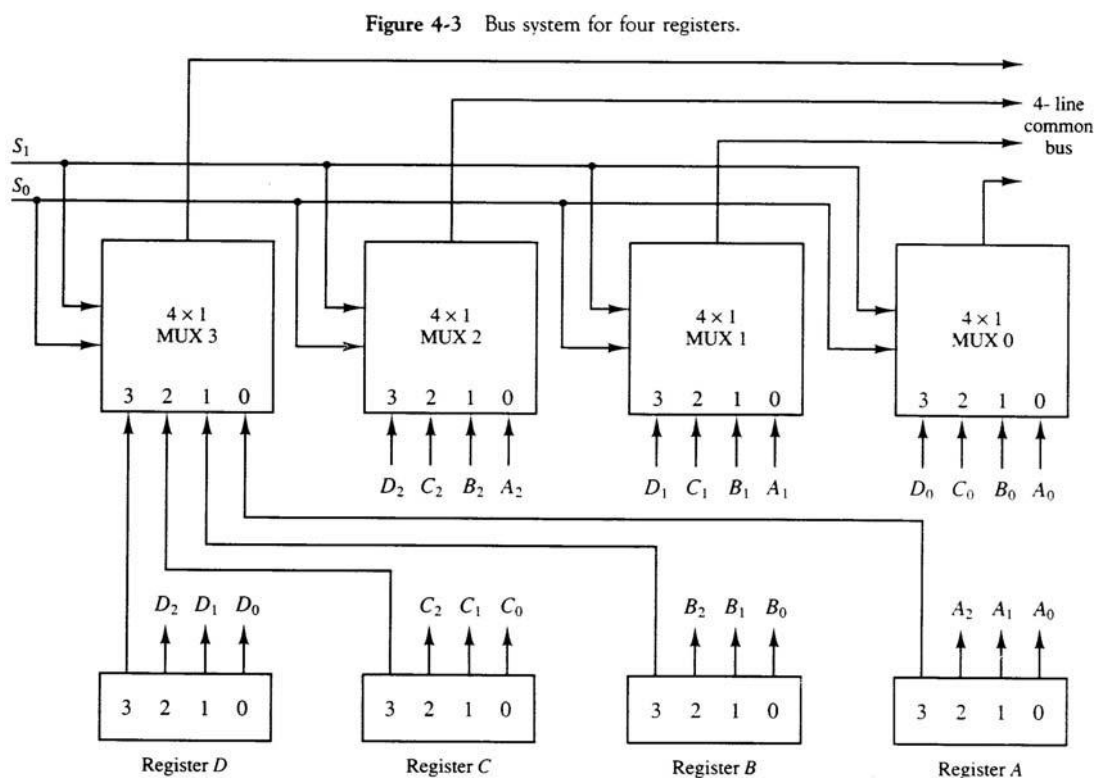

- Multiply and divide are not included as microoperations
- A microoperation is one that can be executed by one clock pulse
- Multiply (divide) is implemented by a sequence of add and shift microoperations (subtract and shift)
- To implement the add microoperation with hardware, we need the registers that hold the data and the digital component that performs the addition
- A full-adder adds two bits and a previous carry



- A binary adder is a digital circuit that generates the arithmetic sum of two binary numbers of any length
- A binary adder is constructed with full-adder circuits connected in cascade
- An n-bit binary adder requires n full-adders

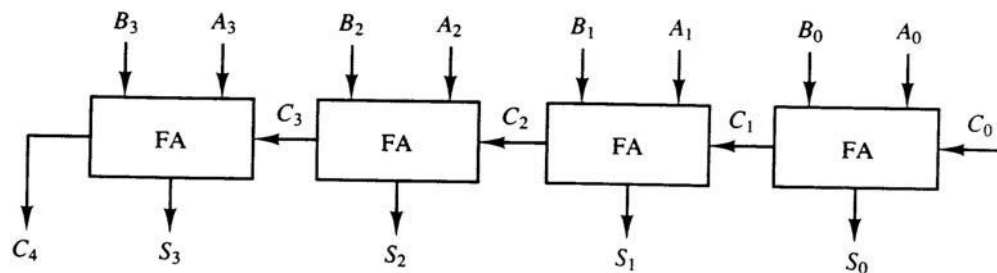

Figure 4-6 4-bit binary adder.

- The subtraction  $A-B$  can be carried out by the following steps
  - Take the 1's complement of  $B$  (invert each bit)
  - Get the 2's complement by adding 1
  - Add the result to  $A$
- The addition and subtraction operations can be combined into one common circuit by including an XOR gate with each full-adder

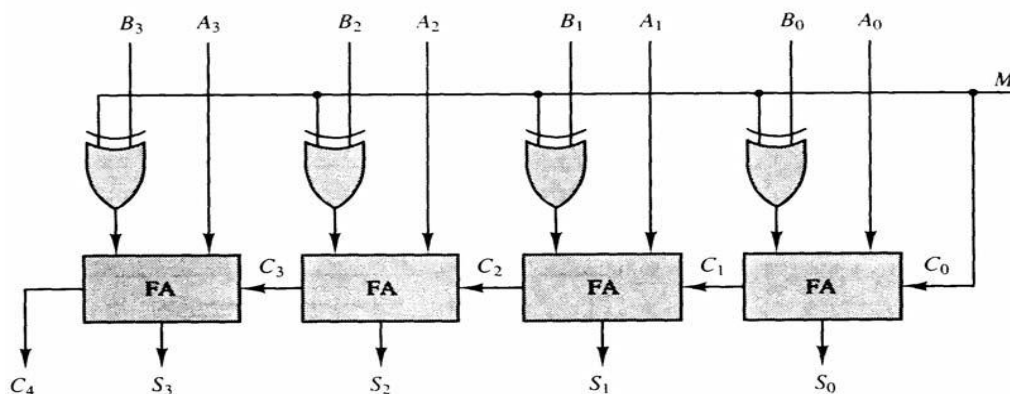

Figure 4-7 4-bit adder-subtractor.

- The increment microoperation adds one to a number in a register
- This can be implemented by using a binary counter – every time the count enable is active, the count is incremented by one
- If the increment is to be performed independent of a particular register, then use half-adders connected in cascade
- An n-bit binary incrementer requires n half-adders

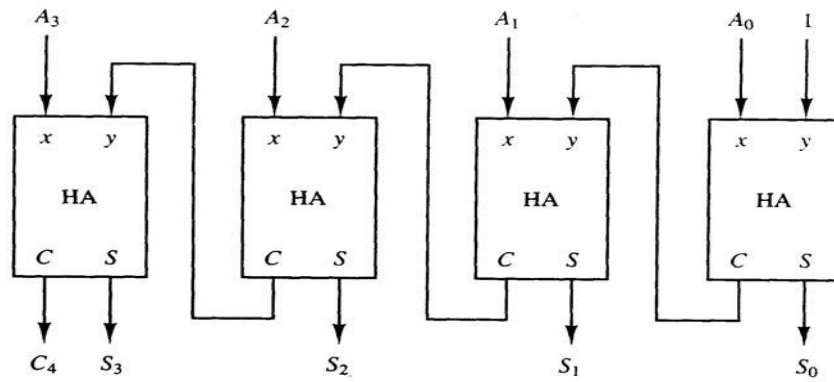

Figure 4-8 4-bit binary incrementer.

- Each of the arithmetic microoperations can be implemented in one composite arithmetic circuit
- The basic component is the parallel adder
- Multiplexers are used to choose between the different operations
- The output of the binary adder is calculated from the following sum:  $D = A + Y + C_{in}$

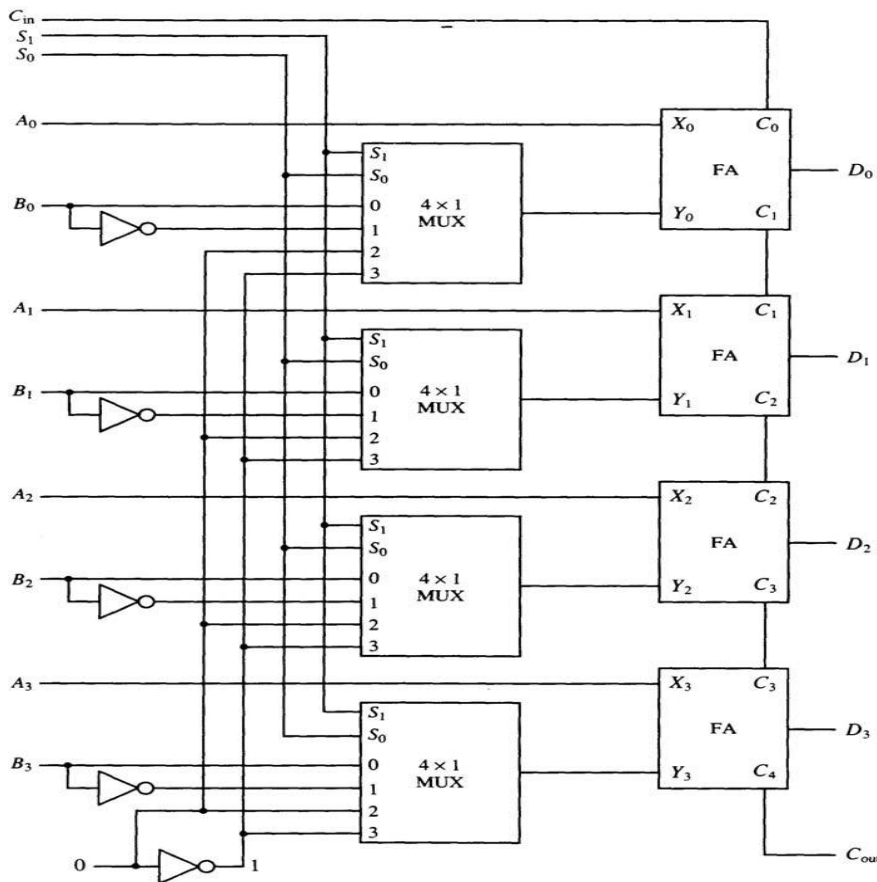

Figure 4-9 4-bit arithmetic circuit.

TABLE 4-4 Arithmetic Circuit Function Table

Select			Input $Y$	Output $D = A + Y + C_{in}$	Microoperation
$S_1$	$S_0$	$C_{in}$			
0	0	0	$B$	$D = A + B$	Add
0	0	1	$B$	$D = A + B + 1$	Add with carry
0	1	0	$\overline{B}$	$D = A + \overline{B}$	Subtract with borrow
0	1	1	$\overline{B}$	$D = A + \overline{B} + 1$	Subtract
1	0	0	0	$D = A$	Transfer $A$
1	0	1	0	$D = A + 1$	Increment $A$
1	1	0	1	$D = A - 1$	Decrement $A$
1	1	1	1	$D = A$	Transfer $A$

### Logic Microoperations

- Logic operations specify binary operations for strings of bits stored in registers and treat each bit separately
- Example: the XOR of R1 and R2 is symbolized by

$$P: R1 \square R1 \oplus R2$$

- Example: R1 = 1010 and R2 = 1100

$$\begin{array}{ll} 1010 & \text{Content of R1} \\ \underline{1100} & \text{Content of R2} \\ 0110 & \text{Content of R1 after } P = 1 \end{array}$$

- Symbols used for logical microoperations:

- OR:  $\square$
- AND:  $\square$
- XOR:  $\oplus$

- The + sign has two different meanings: logical OR and summation
- When + is in a microoperation, then summation
- When + is in a control function, then OR
- Example:

$$P + Q: R1 \square R2 + R3, R4 \square R5 \square R6$$

- There are 16 different logic operations that can be performed with two binary variables

TABLE 4-5 Truth Tables for 16 Functions of Two Variables

$x$	$y$	$F_0$	$F_1$	$F_2$	$F_3$	$F_4$	$F_5$	$F_6$	$F_7$	$F_8$	$F_9$	$F_{10}$	$F_{11}$	$F_{12}$	$F_{13}$	$F_{14}$	$F_{15}$
0	0	0	0	0	0	0	0	0	0	1	1	1	1	1	1	1	1
0	1	0	0	0	0	1	1	1	1	0	0	0	0	1	1	1	1
1	0	0	0	1	1	0	0	1	1	0	0	1	1	0	0	1	1
1	1	0	1	0	1	0	1	0	1	0	1	0	1	0	1	0	1

TABLE 4-6 Sixteen Logic Microoperations

Boolean function	Microoperation	Name
$F_0 = 0$	$F \leftarrow 0$	Clear
$F_1 = xy$	$F \leftarrow A \wedge B$	AND
$F_2 = xy'$	$F \leftarrow A \wedge \overline{B}$	
$F_3 = x$	$F \leftarrow A$	Transfer $A$
$F_4 = x'y$	$F \leftarrow \overline{A} \wedge B$	
$F_5 = y$	$F \leftarrow B$	Transfer $B$
$F_6 = x \oplus y$	$F \leftarrow A \oplus B$	Exclusive-OR
$F_7 = x + y$	$F \leftarrow A \vee B$	OR
$F_8 = (x + y)'$	$F \leftarrow \overline{A \vee B}$	NOR
$F_9 = (x \oplus y)'$	$F \leftarrow \overline{A \oplus B}$	Exclusive-NOR
$F_{10} = y'$	$F \leftarrow \overline{B}$	Complement $B$
$F_{11} = x + y'$	$F \leftarrow A \vee \overline{B}$	
$F_{12} = x'$	$F \leftarrow \overline{A}$	Complement $A$
$F_{13} = x' + y$	$F \leftarrow \overline{A} \vee B$	
$F_{14} = (xy)'$	$F \leftarrow \overline{A \wedge B}$	NAND
$F_{15} = 1$	$F \leftarrow \text{all 1's}$	Set to all 1's

- The hardware implementation of logic microoperations requires that logic gates be inserted for each bit or pair of bits in the registers
- All 16 microoperations can be derived from using four logic gates

Figure 4-10 One stage of logic circuit.

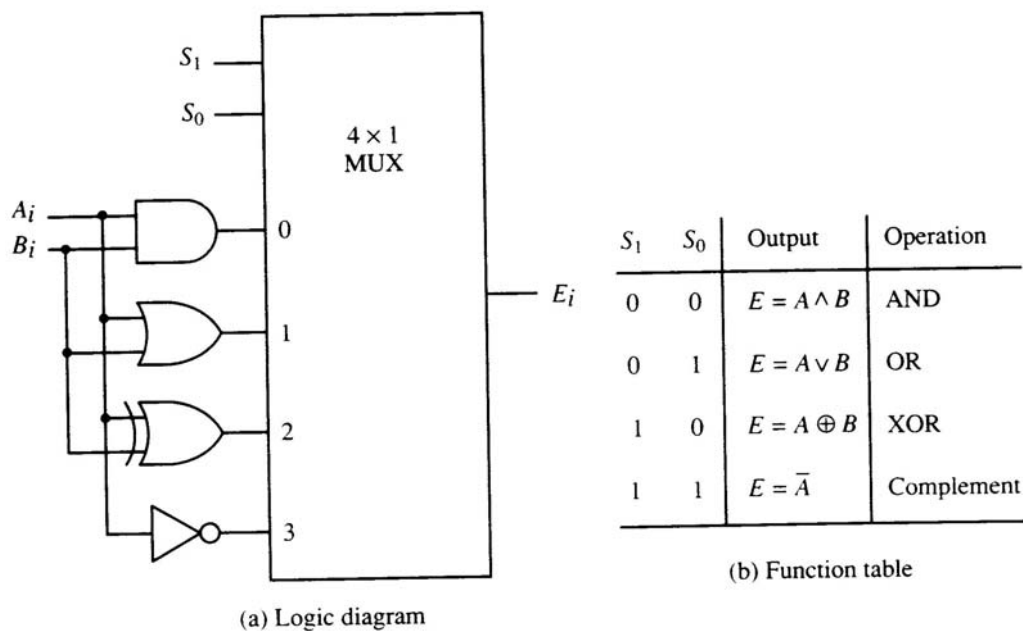

- Logic microoperations can be used to change bit values, delete a group of bits, or insert new bit values into a register
- The selective-set operation sets to 1 the bits in A where there are corresponding 1's in B

```

1010  A before
1100 B (logic operand)
1110  A after

```

$$A \square A \square B$$

- The selective-complement operation complements bits in A where there are corresponding 1's in B

```

1010  A before
1100 B (logic operand)
0110  A after

```

$$A \square A \oplus B$$

- The selective-clear operation clears to 0 the bits in A only where there are corresponding 1's in B

```

1010  A before
1100 B (logic operand)
0010  A after

```

$$A \square A \square B$$

- The mask operation is similar to the selective-clear operation, except that the bits of A are cleared only where there are corresponding 0's in B

```

1010  A before
1100 B (logic operand)
1000  A after

```

$$A \square A \square B$$

- The insert operation inserts a new value into a group of bits
- This is done by first masking the bits to be replaced and then Oring them with the bits to be inserted

```

0110 1010   A before
0000 1111   B (mask)
0000 1010   A after masking

```

```

0000 1010   A before
1001 0000   B (insert)
1001 1010   A after insertion

```

- The clear operation compares the bits in A and B and produces an all 0's result if the two number are equal

```

1010  A
1010  B
0000  A □ A ⊕ B

```

### Shift Microoperations

- Shift microoperations are used for serial transfer of data
- They are also used in conjunction with arithmetic, logic, and other data-processing operations
- There are three types of shifts: logical, circular, and arithmetic
- A logical shift is one that transfers 0 through the serial input
- The symbols shl and shr are for logical shift-left and shift-right by one position R1
  - shl R1
- The circular shift (aka rotate) circulates the bits of the register around the two ends without loss of information
- The symbols cil and cir are for circular shift left and right

**TABLE 4-7** Shift Microoperations

Symbolic designation	Description
$R \leftarrow \text{shl } R$	Shift-left register $R$
$R \leftarrow \text{shr } R$	Shift-right register $R$
$R \leftarrow \text{cil } R$	Circular shift-left register $R$
$R \leftarrow \text{cir } R$	Circular shift-right register $R$
$R \leftarrow \text{ashl } R$	Arithmetic shift-left $R$
$R \leftarrow \text{ashr } R$	Arithmetic shift-right $R$

- The arithmetic shift shifts a signed binary number to the left or right
- To the left is multiplying by 2, to the right is dividing by 2
- Arithmetic shifts must leave the sign bit unchanged
- A sign reversal occurs if the bit in  $R_{n-1}$  changes in value after the shift
- This happens if the multiplication causes an overflow
- An overflow flip-flop  $V_s$  can be used to detect the overflow  $V_s$

$$= R_{n-1} \oplus R_{n-2}$$

- A bi-directional shift unit with parallel load could be used to implement this
- Two clock pulses are necessary with this configuration: one to load the value and another to shift
- In a processor unit with many registers it is more efficient to implement the shift operation with a combinational circuit
- The content of a register to be shifted is first placed onto a common bus and the output is connected to the combinational shifter, the shifted number is then loaded back into the register
- This can be constructed with multiplexers

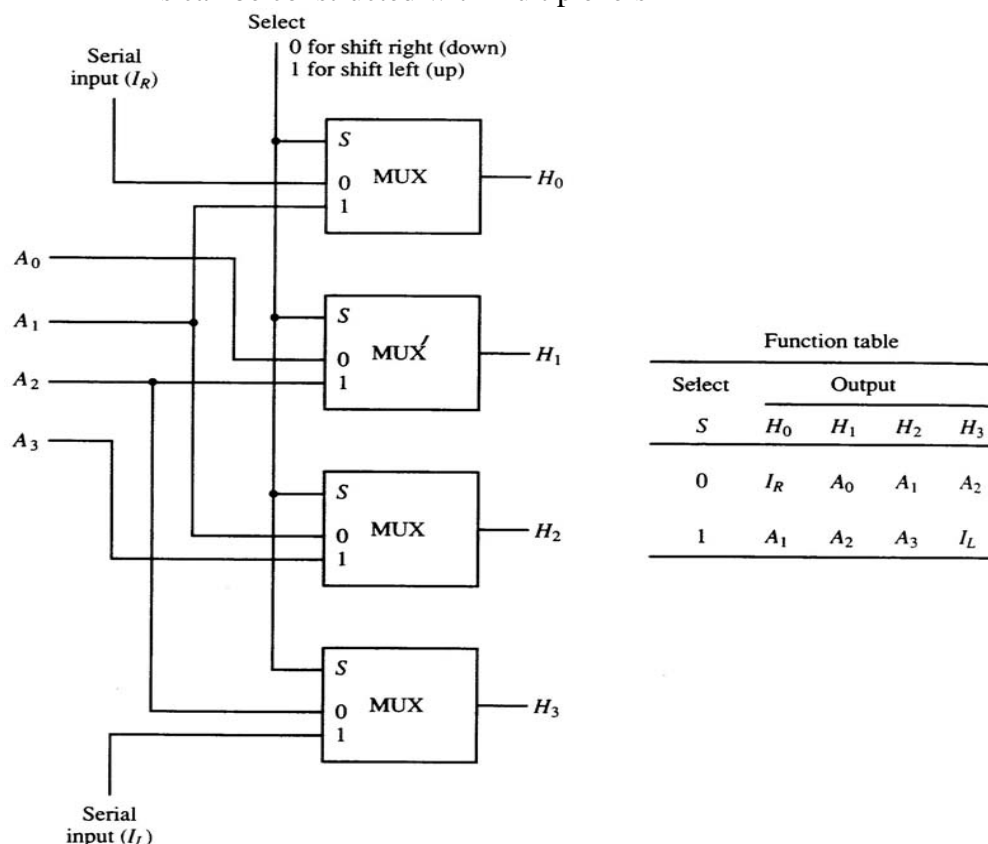

Figure 4-12 4-bit combinational circuit shifter.

### Arithmetic Logic Shift Unit

- The arithmetic logic unit (ALU) is a common operational unit connected to a number of storage registers
- To perform a microoperation, the contents of specified registers are placed in the inputs of the ALU
- The ALU performs an operation and the result is then transferred to a destination register
- The ALU is a combinational circuit so that the entire register transfer operation from the source registers through the ALU and into the destination register can be performed during one clock pulse period



Figure 4-13 One stage of arithmetic logic shift unit.

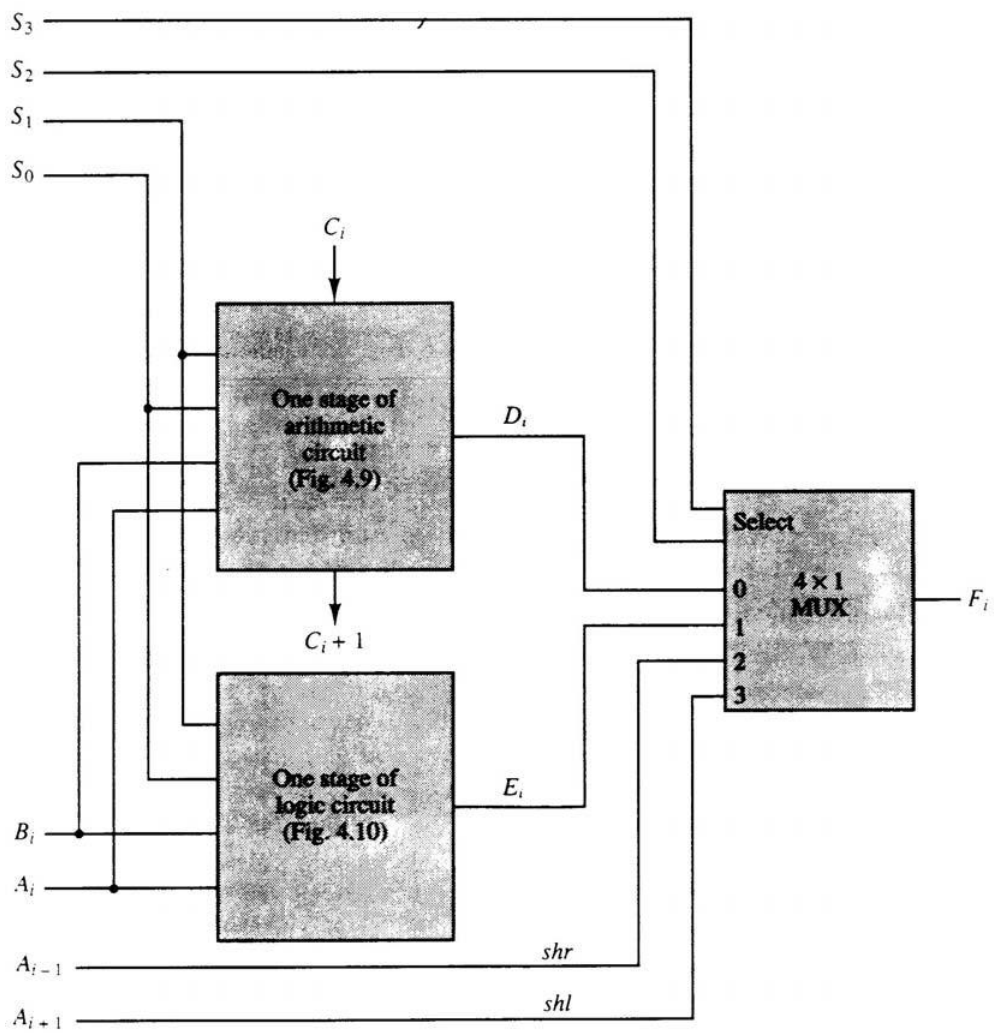



TABLE 4-8 Function Table for Arithmetic Logic Shift Unit

Operation select					Operation	Function
$S_3$	$S_2$	$S_1$	$S_0$	$C_{in}$		
0	0	0	0	0	$F = A$	Transfer $A$
0	0	0	0	1	$F = A + 1$	Increment $A$
0	0	0	1	0	$F = A + B$	Addition
0	0	0	1	1	$F = A + B + 1$	Add with carry
0	0	1	0	0	$F = A + \overline{B}$	Subtract with borrow
0	0	1	0	1	$F = A + \overline{B} + 1$	Subtraction
0	0	1	1	0	$F = A - 1$	Decrement $A$
0	0	1	1	1	$F = A$	Transfer $A$
0	1	0	0	$\times$	$F = A \wedge B$	AND
0	1	0	1	$\times$	$F = A \vee B$	OR
0	1	1	0	$\times$	$F = A \oplus B$	XOR
0	1	1	1	$\times$	$F = \overline{A}$	Complement $A$
1	0	$\times$	$\times$	$\times$	$F = \text{shr } A$	Shift right $A$ into $F$
1	1	$\times$	$\times$	$\times$	$F = \text{shl } A$	Shift left $A$ into $F$

### Basic Computer Organization and Design

Instruction codes. Computer Registers Computer instructions, Timing and Control, Instruction cycle. Memory Reference Instructions, Input – Output and Interrupt, Complete Computer Description.

**Micro Programmed Control:** Control memory, Address sequencing, micro program example, design of control unit, micro Programmed control

### Instruction Formats:

A computer will usually have a variety of instruction code formats. It is the function of the control unit within the CPU to interpret each instruction code and provide the necessary control functions needed to process the instruction.

The format of an instruction is usually depicted in a rectangular box symbolizing the bits of the instruction as they appear in memory words or in a control register. The bits of the instruction are divided into groups called fields. The most common fields found in instruction formats are:

- 1 An operation code field that specifies the operation to be performed.
2. An address field that designates a memory address or a processor registers.
3. A mode field that specifies the way the operand or the effective address is determined.

Other special fields are sometimes employed under certain circumstances, as for example a field that gives the number of shifts in a shift-type instruction.

The operation code field of an instruction is a group of bits that define various processor operations, such as add, subtract, complement, and shift. The bits that define the

mode field of an instruction code specify a variety of alternatives for choosing the operands from the given address.

Operations specified by computer instructions are executed on some data stored in memory or processor registers, Operands residing in processor registers are specified with a register address. A register address is a binary number of  $k$  bits that defines one of  $2^k$  registers in the CPU. Thus a CPU with 16 processor registers R0 through R15 will have a register address field of four bits. The binary number 0101, for example, will designate register R5.

Computers may have instructions of several different lengths containing varying number of addresses. The number of address fields in the instruction format of a computer depends on the internal organization of its registers. Most computers fall into one of three types of CPU organizations:

- 1 Single accumulator organization.
- 2 General register organization.
- 3 Stack organization.

All operations are performed with an implied accumulator register. The instruction format in this type of computer uses one address field. For example, the instruction that specifies an arithmetic addition is defined by an assembly language instruction as ADD.

Where  $X$  is the address of the operand. The ADD instruction in this case results in the operation  $AC \leftarrow AC + M[X]$ .  $AC$  is the accumulator register and  $M[X]$  symbolizes the memory word located at address  $X$ .

An example of a general register type of organization was presented in Fig. 7.1. The instruction format in this type of computer needs three register address fields. Thus the instruction for an arithmetic addition may be written in an assembly language as

ADD            R1, R2, R3

To denote the operation  $R1 \leftarrow R2 + R3$ . The number of address fields in the instruction can be reduced from three to two if the destination register is the same as one of the source registers. Thus the instruction

ADD            R1, R2

Would denote the operation  $R1 \leftarrow R1 + R2$ . Only register addresses for R1 and R2 need be specified in this instruction.

Computers with multiple processor registers use the move instruction with a mnemonic MOV to symbolize a transfer instruction. Thus the instruction

MOV R1, R2

Denotes the transfer  $R1 \leftarrow R2$  (or  $R2 \leftarrow R1$ , depending on the particular computer). Thus transfer-type instructions need two address fields to specify the source and the destination.

General register-type computers employ two or three address fields in their instruction format. Each address field may specify a processor register or a memory word. An instruction symbolized by

ADD R1, X

Would specify the operation  $R1 \leftarrow R + M[X]$ . It has two address fields, one for register R1 and the other for the memory address X.

The stack-organized CPU was presented in Fig. 8-4. Computers with stack organization would have PUSH and POP instructions which require an address field. Thus the instruction

PUSH X

Will push the word at address X to the top of the stack. The stack pointer is updated automatically. Operation-type instructions do not need an address field in stack-organized computers. This is because the operation is performed on the two items that are on top of the stack. The instruction ADD in a stack computer consists of an operation code only with no address field. This operation has the effect of popping the two top numbers from the stack, adding the numbers, and pushing the sum into the stack. There is no need to specify operands with an address field since all operands are implied to be in the stack.

To illustrate the influence of the number of addresses on computer programs, we will evaluate the arithmetic statement  $X = (A + B) * (C + D)$ .

Using zero, one, two, or three address instruction. We will use the symbols ADD, SUB, MUL, and DIV for the four arithmetic operations; MOV for the transfer-type operation; and LOAD and STORE for transfers to and from memory and AC register. We will assume that the operands are in memory addresses A, B, C, and D, and the result must be stored in memory at address X.

### **Three-Address Instructions**

Computers with three-address instruction formats can use each address field to specify either a processor register or a memory operand. The program in assembly language that evaluates  $X = (A + B) * (C + D)$  is shown below, together with comments that explain the register transfer operation of each instruction.

```

ADD   R1, A, B   R1 ← M [A] + M [B]
ADD   R2, C, D   R2 ← M [C] + M [D]

MUL X, R1, R2   M [X] ← R1 * R2

```

It is assumed that the computer has two processor registers, R1 and R2. The symbol M [A] denotes the operand at memory address symbolized by A.

The advantage of the three-address format is that it results in short programs when evaluating arithmetic expressions. The disadvantage is that the binary-coded instructions require too many bits to specify three addresses. An example of a commercial computer that uses three-address instructions is the Cyber 170. The instruction formats in the Cyber computer are restricted to either three register address fields or two register address fields and one memory address field.

### **Two-Address Instructions**

Two address instructions are the most common in commercial computers. Here again each address field can specify either a processor register or a memory word. The program to evaluate  $X = (A + B) * (C + D)$  is as follows:

```

MOV   R1, A      R1 ← M [A]
ADD   R1, B      R1 ← R1 + M [B]
MOV   R2, C      R2 ← M [C]
ADD   R2, D      R2 ← R2 + M [D]
MUL   R1, R2     R1 ← R1 * R2
MOV   X, R1      M [X] ← R1

```

The MOV instruction moves or transfers the operands to and from memory and processor registers. The first symbol listed in an instruction is assumed to be both a source and the destination where the result of the operation is transferred.

### **One-Address Instructions**

One-address instructions use an implied accumulator (AC) register for all data manipulation. For multiplication and division there is a need for a second register. However, here we will neglect the second and assume that the AC contains the result of all operations. The program to evaluate  $X = (A + B) * (C + D)$  is

```

LOAD   A        AC ← M [A]
ADD    B        AC ← A [C] + M [B]
STORE  T        M [T] ← AC
LOAD   C        AC ← M [C]
ADD    D        AC ← AC + M [D]

```

MUL	T	$AC \leftarrow AC * M [T]$
STORE	X	$M [X] \leftarrow AC$

All operations are done between the AC register and a memory operand. T is the address of a temporary memory location required for storing the intermediate result.

### Zero-Address Instructions

A stack-organized computer does not use an address field for the instructions ADD and MUL. The PUSH and POP instructions, however, need an address field to specify the operand that communicates with the stack. The following program shows how  $X = (A + B) * (C + D)$  will be written for a stack organized computer. (TOS stands for top of stack)

PUSH	A	$TOS \leftarrow A$
PUSH	B	$TOS \leftarrow B$
ADD		$TOS \leftarrow (A + B)$
PUSH	C	$TOS \leftarrow C$
PUSH	D	$TOS \leftarrow D$
ADD		$TOS \leftarrow (C + D)$
MUL		$TOS \leftarrow (C + D) * (A + B)$
POP	X	$M [X] \leftarrow TOS$

To evaluate arithmetic expressions in a stack computer, it is necessary to convert the expression into reverse Polish notation. The name “zero-address” is given to this type of computer because of the absence of an address field in the computational instructions.

### Instruction Codes

A set of instructions that specify the operations, operands, and the sequence by which processing has to occur. An instruction code is a group of bits that tells the computer to perform a specific operation part.

### Format of Instruction

The format of an instruction is depicted in a rectangular box symbolizing the bits of an instruction. Basic fields of an instruction format are given below:

1. An operation code field that specifies the operation to be performed.
2. An address field that designates the memory address or register.
3. A mode field that specifies the way the operand of effective address is determined.

Computers may have instructions of different lengths containing varying number of addresses. The number of address field in the instruction format depends upon the internal organization of its registers.

## Addressing Modes

To understand the various addressing modes to be presented in this section, it is imperative that we understand the basic operation cycle of the computer. The control unit of a computer is designed to go through an instruction cycle that is divided into three major phases:

1. Fetch the instruction from memory
2. Decode the instruction.
3. Execute the instruction.

There is one register in the computer called the program counter or PC that keeps track of the instructions in the program stored in memory. PC holds the address of the instruction to be executed next and is incremented each time an instruction is fetched from memory. The decoding done in step 2 determines the operation to be performed, the addressing mode of the instruction and the location of the operands. The computer then executes the instruction and returns to step 1 to fetch the next instruction in sequence.

In some computers the addressing mode of the instruction is specified with a distinct binary code, just like the operation code is specified. Other computers use a single binary code that designates both the operation and the mode of the instruction. Instructions may be defined with a variety of addressing modes, and sometimes, two or more addressing modes are combined in one instruction.

1. The operation code specifies the operation to be performed. The mode field is used to locate the operands needed for the operation. There may or may not be an address field in the instruction. If there is an address field, it may designate a memory address or a processor register. Moreover, as discussed in the preceding section, the instruction may have more than one address field, and each address field may be associated with its own particular addressing mode.

Although most addressing modes modify the address field of the instruction, there are two modes that need no address field at all. These are the implied and immediate modes.

**1 Implied Mode:** In this mode the operands are specified implicitly in the definition of the instruction. For example, the instruction “complement accumulator” is an implied-mode instruction because the operand in the accumulator register is implied in the definition of the instruction. In fact, all register reference instructions that use an accumulator are implied-mode instructions.



**Figure 1:** Instruction format with mode field

Zero-address instructions in a stack-organized computer are implied-mode

instructions since the operands are implied to be on top of the stack.

**2 Immediate Mode:** In this mode the operand is specified in the instruction itself. In other words, an immediate-mode instruction has an operand field rather than an address field. The operand field contains the actual operand to be used in conjunction with the operation specified in the instruction. Immediate-mode instructions are useful for initializing registers to a constant value.

It was mentioned previously that the address field of an instruction may specify either a memory word or a processor register. When the address field specifies a processor register, the instruction is said to be in the register mode.

**3 Register Mode:** In this mode the operands are in registers that reside within the CPU. The particular register is selected from a register field in the instruction. A  $k$ -bit field can specify any one of  $2^k$  registers.

**4 Register Indirect Mode:** In this mode the instruction specifies a register in the CPU whose contents give the address of the operand in memory. In other words, the selected register contains the address of the operand rather than the operand itself. Before using a register indirect mode instruction, the programmer must ensure that the memory address for the operand is placed in the processor register with a previous instruction. A reference to the register is then equivalent to specifying a memory address. The advantage of a register indirect mode instruction is that the address field of the instruction uses fewer bits to select a register than would have been required to specify a memory address directly.

**5 Auto increment or Auto decrement Mode:** This is similar to the register indirect mode except that the register is incremented or decremented after (or before) its value is used to access memory. When the address stored in the register refers to a table of data in memory, it is necessary to increment or decrement the register after every access to the table. This can be achieved by using the increment or decrement instruction. However, because it is such a common requirement, some computers incorporate a special mode that automatically increments or decrements the content of the register after data access.

The address field of an instruction is used by the control unit in the CPU to obtain the operand from memory. Sometimes the value given in the address field is the address of the operand, but sometimes it is just an address from which the address of the operand is calculated. To differentiate among the various addressing modes it is necessary to distinguish between the address part of the instruction and the effective address used by the

control when executing the instruction. The effective address is defined to be the memory address obtained from the computation dictated by the given addressing mode. The effective address is the address of the operand in a computational-type instruction. It is the address where control branches in response to a branch-type instruction. We have already defined two addressing modes in previous chapter.

**6 Direct Address Mode:** In this mode the effective address is equal to the address part of the instruction. The operand resides in memory and its address is given directly by the address field of the instruction. In a branch-type instruction the address field specifies the actual branch address.

**7 Indirect Address Mode:** In this mode the address field of the instruction gives the address where the effective address is stored in memory. Control fetches the instruction from memory and uses its address part to access memory again to read the effective address.

**8 Relative Address Mode:** In this mode the content of the program counter is added to the address part of the instruction in order to obtain the effective address. The address part of the instruction is usually a signed number (in 2's complement representation) which can be either positive or negative. When this number is added to the content of the program counter, the result produces an effective address whose position in memory is relative to the address of the next instruction. To clarify with an example, assume that the program counter contains the number 825 and the address part of the instruction contains the number 24. The instruction at location 825 is read from memory during the fetch phase and the program counter is then incremented by one to  $826 + 24 = 850$ . This is 24 memory locations forward from the address of the next instruction. Relative addressing is often used with branch-type instructions when the branch address is in the area surrounding the instruction word itself. It results in a shorter address field in the instruction format since the relative address can be specified with a smaller number of bits compared to the number of bits required to designate the entire memory address.

**9 Indexed Addressing Mode:** In this mode the content of an index register is added to the address part of the instruction to obtain the effective address. The index register is a special CPU register that contains an index value. The address field of the instruction defines the beginning address of a data array in memory. Each operand in the array is stored in memory relative to the beginning address. The distance between the beginning address and the address of the operand is the index value stored in the index register. Any operand in the array can be accessed with the same instruction provided that the



index register contains the correct index value. The index register can be incremented to facilitate access to consecutive operands. Note that if an index-type instruction does not include an address field in its format, the instruction converts to the register indirect mode of operation. Some computers dedicate one CPU register to function solely as an index register. This register is involved implicitly when the index-mode instruction is used. In computers with many processor registers, any one of the CPU registers can contain the index number. In such a case the register must be specified explicitly in a register field within the instruction format.

**10 Base Register Addressing Mode:** In this mode the content of a base register is added to the address part of the instruction to obtain the effective address. This is similar to the indexed addressing mode except that the register is now called a base register instead of an index register. The difference between the two modes is in the way they are used rather than in the way that they are computed. An index register is assumed to hold an index number that is relative to the address part of the instruction. A base register is assumed to hold a base address and the address field of the instruction gives a displacement relative to this base address. The base register addressing mode is used in computers to facilitate the relocation of programs in memory. When programs and data are moved from one segment of memory to another, as required in multiprogramming systems, the address values of the base register requires updating to reflect the beginning of a new memory segment.

### Numerical Example

		Address	Memory
$PC = 200$		200	Load to AC
		201	Address = 500
$R1 = 400$		202	Next instruction
$XR = 100$		399	450
$AC$		400	700
		500	800
		600	900
		702	325
		800	300

Figure 8-7 Numerical example for addressing modes.

TABLE 8-4 Tabular List of Numerical Example

Addressing Mode	Effective Address	Content of AC
Direct address	500	800
Immediate operand	201	500
Indirect address	800	300
Relative address	702	325
Indexed address	600	900
Register	—	400
Register indirect	400	700
Autoincrement	400	700
Autodecrement	399	450

### Computer Registers

- Data Register(**DR**) : hold the operand(Data) read from memory
  - Accumulator Register(**AC**) : general purpose processing register
  - Instruction Register(**IR**) : hold the instruction read from memory
  - Temporary Register(**TR**) : hold a temporary data during processing
  - Address Register(**AR**) : hold a memory address, 12 bit width
  - Program Counter(**PC**) :
    - » hold the address of the next instruction to be read from memory after the current instruction is executed
    - » Instruction words are read and executed in sequence unless a branch instruction is encountered
    - » A branch instruction calls for a transfer to a nonconsecutive instruction in the program
    - » The address part of a branch instruction is transferred to PC to become the address of the next instruction
  - Input Register(INPR) : receive an 8-bit character from an input device*
  - Output Register(**OUTR**) : hold an 8-bit character for an output device
- The following registers are used in Mano's example computer.

Register symbol	Number of bits	Register name	Register Function
DR	16	Data register	Holds memory operands
AR	12	Address register	Holds address for memory
AC	16	Accumulator	Processor register
IR	16	Instruction register	Holds instruction code
PC	12	Program counter	Holds address of instruction
TR	16	Temporary register	Holds temporary data
INPR	8	Input register	Holds input character
OUTR	8	Output register	Holds output character

### Computer Instructions:

The basic computer has 16 bit instruction register (IR) which can denote either memory reference or register reference or input-output instruction.

1. **Memory Reference** – These instructions refer to memory address as an operand. The other operand is always accumulator. Specifies 12 bit address, 3 bit opcode (other than 111) and 1 bit addressing mode for direct and indirect addressing.

#### Example

IR register contains = 0001XXXXXXXXXXXX, i.e. ADD after fetching and decoding of instruction we find out that it is a memory reference instruction for ADD operation.

Hence,  $DR \leftarrow M[AR]$   
 $AC \leftarrow AC + DR, SC \leftarrow 0$

2. **Register Reference** – These instructions perform operations on registers rather than memory addresses. The IR(14-12) is 111 (differentiates it from memory reference) and IR(15) is 0 (differentiates it from input/output instructions). The rest 12 bits specify register operation.

#### Example

IR register contains = 0111001000000000, i.e. CMA after fetch and decode cycle we find out that it is a register reference instruction for complement accumulator.

Hence,  $AC \leftarrow \sim AC$

3. **Input/Output** – These instructions are for communication between computer and outside environment. The IR(14-12) is 111 (differentiates it from memory reference) and IR(15) is 1 (differentiates it from register reference instructions). The rest 12 bits specify I/O operation.

#### Example

IR register contains = 1111100000000000, i.e. INP after fetch and decode cycle we find out that it is an input/output instruction for inputting character. Hence, INPUT character from peripheral device.

### Timing and Control

All sequential circuits in the Basic Computer CPU are driven by a master clock, with the exception of the INPR register. At each clock pulse, the control unit sends control signals to control inputs of the bus, the registers, and the ALU.

Control unit design and implementation can be done by two general methods:

- A hardwired control unit is designed from scratch using traditional digital logic design techniques to produce a minimal, optimized circuit. In other words, the control unit is like an ASIC (application-specific integrated circuit).
- A microprogrammed control unit is built from some sort of ROM. The desired control signals are simply stored in the ROM, and retrieved in sequence to drive the microoperations needed by a particular instruction.

### Instruction Cycle

The CPU performs a sequence of microoperations for each instruction. The sequence for each instruction of the Basic Computer can be refined into 4 abstract phases:

1. Fetch instruction
2. Decode
3. Fetch operand
4. Execute

Program execution can be represented as a top-down design:

1. Program execution
  - a. Instruction 1
    - i. Fetch instruction
    - ii. Decode
    - iii. Fetch operand
    - iv. Execute
  - b. Instruction 2
    - i. Fetch instruction
    - ii. Decode
    - iii. Fetch operand
    - iv. Execute
  - c. Instruction 3 ...

Program execution begins with:

$PC \leftarrow$  address of first instruction,  $SC \leftarrow 0$

After this, the SC is incremented at each clock cycle until an instruction is completed, and then it is cleared to begin the next instruction. This process repeats until a HLT instruction is executed, or until the power is shut off.

### Instruction Fetch and Decode

The instruction fetch and decode phases are the same for all instructions, so the control functions and microoperations will be independent of the instruction code.

Everything that happens in this phase is driven entirely by timing variables  $T_0$ ,  $T_1$  and  $T_2$ . Hence, all control inputs in the CPU during fetch and decode are functions of these three variables alone.

$T_0$ :  $AR \leftarrow PC$

$T_1$ :  $IR \leftarrow M[AR]$ ,  $PC \leftarrow PC + 1$

$T_2$ :  $D_{0-7} \leftarrow \text{decoded } IR(12-14)$ ,  $AR \leftarrow IR(0-11)$ ,  $I \leftarrow IR(15)$

For every timing cycle, we assume  $SC \leftarrow SC + 1$  unless it is stated that  $SC \leftarrow 0$ .

### Micro Programmed Control:

#### Control Memory

- The control unit in a digital computer initiates sequences of microoperations
- The complexity of the digital system is derived from the number of sequences that are performed
- When the control signals are generated by hardware, it is hardwired
- In a bus-oriented system, the control signals that specify microoperations are groups of bits that select the paths in multiplexers, decoders, and ALUs.
- The control unit initiates a series of sequential steps of microoperations
- The control variables can be represented by a string of 1's and 0's called a control word
- A microprogrammed control unit is a control unit whose binary control variables are stored in memory
- A sequence of microinstructions constitutes a microprogram
- The control memory can be a read-only memory
- Dynamic microprogramming permits a microprogram to be loaded and uses a writable control memory
- A computer with a microprogrammed control unit will have two separate memories: a main memory and a control memory
- The microprogram consists of microinstructions that specify various internal control signals for execution of register microoperations
- These microinstructions generate the microoperations to:
  - fetch the instruction from main memory
  - evaluate the effective address
  - execute the operation
  - return control to the fetch phase for the next instruction
- The control memory address register specifies the address of the microinstruction
- The control data register holds the microinstruction read from memory
- The microinstruction contains a control word that specifies one or more microoperations for the data processor
- The location for the next microinstruction may, or may not be the next in sequence
- Some bits of the present microinstruction control the generation of the address of the next microinstruction
- The next address may also be a function of external input conditions
- While the microoperations are being executed, the next address is computed in the next

address generator circuit (sequencer) and then transferred into the CAR to read the next microinstructions

- Typical functions of a sequencer are:
  - incrementing the CAR by one
  - loading into the CAR and address from control memory
  - transferring an external address
  - loading an initial address to start the control operations
- A clock is applied to the CAR and the control word and next-address information are taken directly from the control memory
- The address value is the input for the ROM and the control work is the output
- No read signal is required for the ROM as in a RAM
  
- The main advantage of the microprogrammed control is that once the hardware configuration is established, there should be no need for h/w or wiring changes
- To establish a different control sequence, specify a different set of microinstructions for control memory

### Address Sequencing

- Microinstructions are stored in control memory in groups, with each group specifying a routine
- Each computer instruction has its own microprogram routine to generate the microoperations
- The hardware that controls the address sequencing of the control memory must be capable of sequencing the microinstructions within a routine and be able to branch from one routine to another
- Steps the control must undergo during the execution of a single computer instruction:
  - Load an initial address into the CAR when power is turned on in the computer. This address is usually the address of the first microinstruction that activates the instruction fetch routine – IR holds instruction
  - The control memory then goes through the routine to determine the effective address of the operand – AR holds operand address
  - The next step is to generate the microoperations that execute the instruction by considering the opcode and applying a mapping
  - After execution, control must return to the fetch routine by executing an unconditional branch
- The microinstruction in control memory contains a set of bits to initiate microoperations in computer registers and other bits to specify the method by which the next address is obtained
- Conditional branching is obtained by using part of the microinstruction to select a specific status bit in order to determine its condition
- The status conditions are special bits in the system that provide parameter information such as the carry-out of an adder, the sign bit of a number, the mode bits of an instruction, and i/o status conditions
- The status bits, together with the field in the microinstruction that specifies a branch address, control the branch logic
- The branch logic tests the condition, if met then branches, otherwise, increments the CAR

- If there are 8 status bit conditions, then 3 bits in the microinstruction are used to specify the condition and provide the selection variables for the multiplexer
- For unconditional branching, fix the value of one status bit to be one load the branch address from control memory into the CAR
- A special type of branch exists when a microinstruction specifies a branch to the first word in control memory where a microprogram routine is located
- The status bits for this type of branch are the bits in the opcode
- Assume an opcode of four bits and a control memory of 128 locations
- The mapping process converts the 4-bit opcode to a 7-bit address for control memory
- This provides for each computer instruction a microprogram routine with a capacity of four microinstructions
  
- Subroutines are programs that are used by other routines to accomplish a particular task and can be called from any point within the main body of the microprogram
- Frequently many microprograms contain identical sections of code
- Microinstructions can be saved by employing subroutines that use common sections of microcode
- Microprograms that use subroutines must have a provision for storing the return address during a subroutine call and restoring the address during a subroutine return
- A subroutine register is used as the source and destination for the addresses

### UNIT 3

**Syllabus:**

Central Processing Unit organization: General Register Organization, Stack organization, Instruction formats, Addressing modes, Data Transfer and Manipulation, Program Control, CISC and RISC processors

Control unit design: Design approaches, Control memory, Address sequencing, micro program example, design of CU. Micro Programmed Control.

---

#### Computer Processing Unit Organization

##### Introduction to CPU

The operation or task that must perform by CPU is:

- **Fetch Instruction:** The CPU reads an instruction from memory.
- **Interpret Instruction:** The instruction is decoded to determine what action is required.
- **Fetch Data:** The execution of an instruction may require reading data from memory or I/O module.
- **Process data:** The execution of an instruction may require performing some arithmetic or logical operation on data.
- **Write data:** The result of an execution may require writing data to memory or an I/O module.

To do these tasks, it should be clear that the CPU needs to store some data temporarily. It must remember the location of the last instruction so that it can know where to get the next instruction. It needs to store instructions and data temporarily while an instruction is being executed. In other words, the CPU needs a small internal memory. These storage locations are generally referred as registers.

The major components of the CPU are an arithmetic and logic unit (ALU) and a control unit (CU). The ALU does the actual computation or processing of data. The CU controls the movement of data and instruction into and out of the CPU and controls the operation of the ALU.

The CPU is connected to the rest of the system through system bus. Through system bus, data or information gets transferred between the CPU and the other component of the system. The system bus may have three components:

**Data Bus:** Data bus is used to transfer the data between main memory and CPU.

**Address Bus:** Address bus is used to access a particular memory location by putting the address of the memory location.

**Control Bus:** Control bus is used to provide the different control signal generated by CPU to different part of the system.

As for example, memory read is a signal generated by CPU to indicate that a memory read operation has to be performed. Through control bus this signal is transferred to memory module to indicate the required operation.



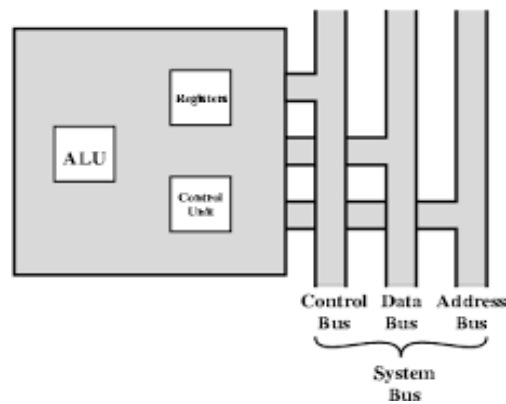
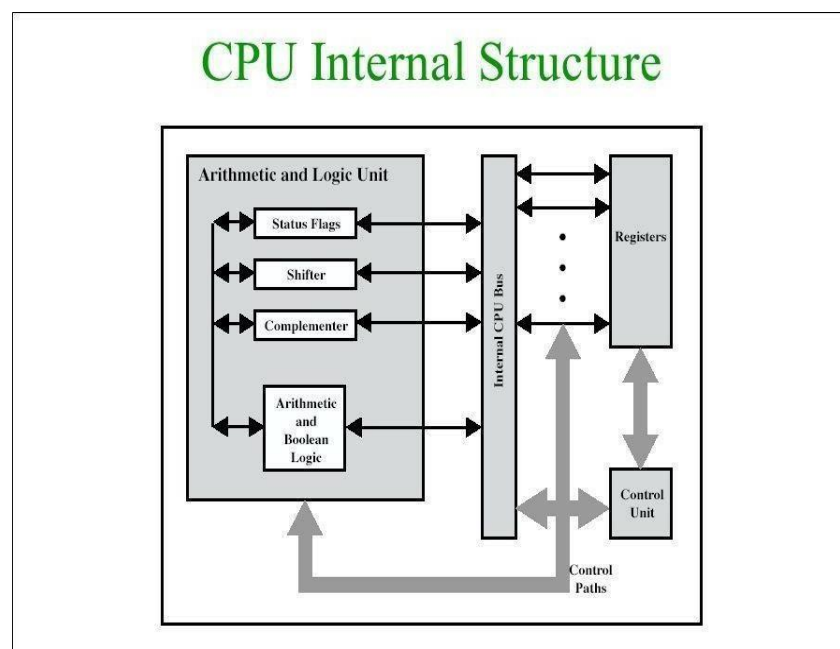

Figure 1: CPU with the system bus.

There are three basic components of CPU: register bank, ALU and Control Unit. There are several data movements between these units and for that an internal CPU bus is used. Internal CPU bus is needed to transfer data between the various registers and the ALU.



Dr. Wang

Figure 2 : Internal Structure of CPU

### Stack Organization:

A useful feature that is included in the CPU of most computers is a stack or last in, first out (LIFO) list. A stack is a storage device that stores information in such a manner that the item stored last is the first item retrieved. The operation of a stack can be compared to a stack of trays. The last tray placed on top of the stack is the first to be taken off.

The stack in digital computers is essentially a memory unit with an address register that can only( after an initial value is loaded in to it).The register that hold the address for the stack is called a stack pointer (SP) because its value always points at the top item in stack. Contrary to a stack of trays where the tray it self may be taken out or inserted, the physical registers of a stack are always available for reading or writing.

The two operations of a stack are the insertion and deletion of items. The operation of insertion is called PUSH because it can be thought of as the result of pushing a new item on top. The operation of deletion is called POP because it can be thought of as the result of removing one item so that the stack pops up. However, nothing is physically pushed or popped in a computer stack. These operations are simulated by incrementing or decrementing the stack pointer register.

### Register stack:

A stack can be placed in a portion of a large memory or it can be organized as a collection of a finite number of memory words or registers. Figure X shows the organization of a 64-word register stack. The stack pointer register SP contains a binary number whose value is equal to the address of the word that is currently on top of the stack. Three items are placed in the stack: A, B, and C in the order. Item C is on the top of the stack so that the content of SP is now 3. To remove the top item, the stack is popped by reading the memory word at address 3 and decrementing the content of SP. Item B is now on top of the stack since SP holds address 2. To insert a new item, the stack is pushed by incrementing SP and writing a word in the next higher location in the stack. Note that item C has been read out but not physically removed. This does not matter because when the stack is pushed, a new item is written in its place.

In a 64-word stack, the stack pointer contains 6 bits because  $2^6 = 64$ . Since SP has only six bits, it cannot exceed a number greater than 63 (111111 in binary). When 63 is incremented by 1, the result is 0 since  $111111 + 1 = 1000000$  in binary, but SP can accommodate only the six least significant bits. Similarly, when 000000 is decremented by 1, the result is 111111. The one-bit register Full is set to 1 when the stack is full, and the one-bit register Empty is set to 1 when the stack is empty of items. DR is the data register that holds the binary data to be written in to or read out of the stack.

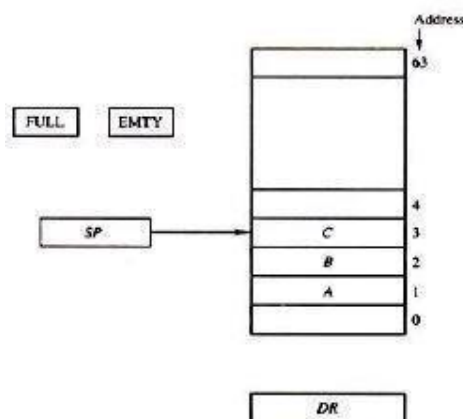

Figure 3: Block Diagram Of A 64-Word Stack

Initially, SP is cleared to 0, Empty is set to 1, and Full is cleared to 0, so that SP points to the word at address 0 and the stack is marked empty and not full. If the stack is not full, a new item is inserted with a push operation. The push operation is implemented with the following sequence of micro-operations.

$SP \leftarrow SP + 1$  (Increment stack pointer)  
 $M(SP) \leftarrow DR$  (Write item on top of the stack)  
 if (sp=0) then (Full  $\leftarrow$  1) (Check if stack is full)  
 Empty  $\leftarrow$  0 (Marked the stack not empty)

The stack pointer is incremented so that it points to the address of the next-higher word. A memory write operation inserts the word from DR into the top of the stack. Note that SP holds the address of the top of the stack and that  $M(SP)$  denotes the memory word specified by the address presently available in SP, the first item stored in the stack is at address 1. The last item is stored at address 0, if SP reaches 0, the stack is full of item, so FULL is set to 1. This condition is reached if the top item prior to the last push was in location 63 and after increment SP, the last item stored in location 0. Once an item is stored in location 0, there are no more empty register in the stack. If an item is written in the stack, Obviously the stack can not be empty, so EMTY is cleared to 0.

$DR \leftarrow M[SP]$	Read item from the top of stack
$SP \leftarrow SP - 1$	Decrement stack Pointer
if( $SP=0$ ) then (Emty $\leftarrow 1$ )	Check if stack is empty
$FULL \leftarrow 0$	Mark the stack not full

The top item is read from the stack into DR. The stack pointer is then decremented. if its value reaches zero, the stack is empty, so Emty is set to 1. This condition is reached if the item read was in location 1. once this item is read out , SP is decremented and reaches the value 0, which is the initial value of SP. Note that if a pop operation reads the item from location 0 and then SP is decremented, SP changes to 11111, which is equal to decimal 63. In this configuration, the word in address 0 receives the last item in the stack. Note also that an erroneous operation will result if the stack is pushed when  $FULL=1$  or popped when  $EMTY =1$ .

### Memory Stack :

A stack can exist as a stand-alone unit as in figure 4 or can be implemented in a random access memory attached to CPU. The implementation of a stack in the CPU is done by assigning a portion of memory to a stack operation and using a processor register as a stack pointer. Figure shows a portion of computer memory partitioned in to three segment program, data and stack. The program counter PC points at the address of the next instruction in the program. The address register AR points at an array of data. The stack pointer SP points at the top of the stack. The three register are connected to a common address bus, and either one can provide an address for memory. PC is used during the fetch phase to read an instruction. AR is used during the execute phase to read an operand. SP is used to push or POP items into or from the stack.

As show in figure :4 the initial value of SP is 4001 and the stack grows with decreasing addresses. Thus the first item stored in the stack is at address 4000, the second item is stored at address 3999, and the last address hat can be used for the stack is 3000. No previous are available for stack limit checks. We assume that the items in the stack communicate with a data register DR. A new item is inserted with the push operation as follows.

$SP \leftarrow SP - 1$   
 $M[SP] \leftarrow DR$

The stack pointer is decremented so that it points at the address of the next word. A Memory write operation insertion the word from DR into the top of the stack. A new item is deleted with a pop operation as follows.

$DR \leftarrow M[SP]$   
 $SP \leftarrow SP + 1$

The top item is read from the stack in to DR. The stack pointer is then incremented to point at the next item in the stack.

Most computer do not provide hardware to check for stack overflow (FULL) or underflow (Empty). The stack limit can be checked by using two processor register : one to hold upper limit and other hold the lower limit. after the pop or push operation SP is compared with lower or upper limit register.

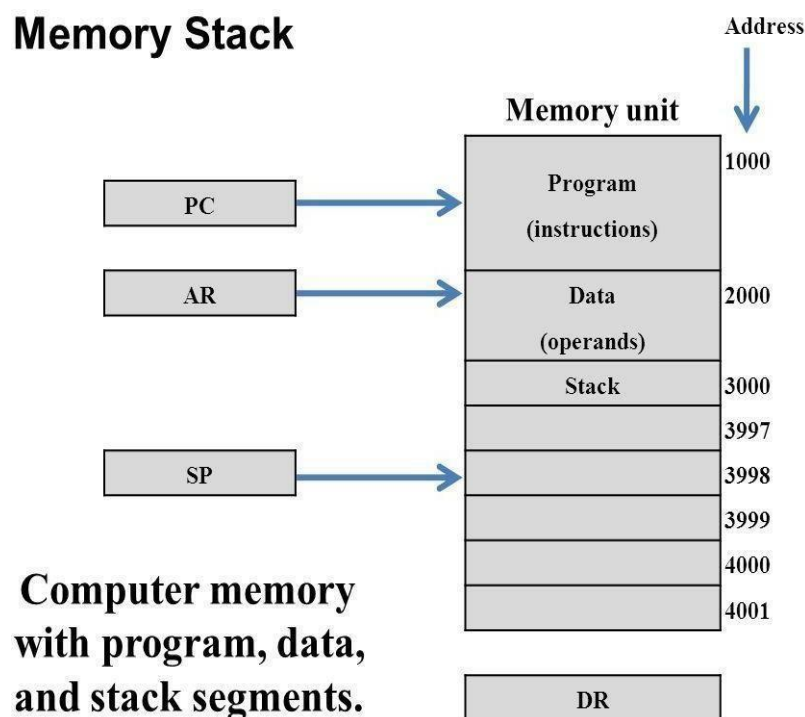

Figure 4: computer memory with program, data and stack segments

### INSTRUCTION FORMATS:

We know that a machine instruction has an opcode and zero or more operands. Encoding an instruction set can be done in a variety of ways. Architectures are differentiated from one another by the number of bits allowed per instruction (16, 32, and 64 are the most common), by the number of operands allowed per instruction, and by the types of instructions and data each can process. More specifically, instruction sets are differentiated by the following features:

1. Operand storage in the CPU (data can be stored in a stack structure or in registers)
2. Number of explicit operands per instruction (zero, one, two, and three being the most common)
3. Operand location (instructions can be classified as register-to-register, register-to-memory or memory-to-memory, which simply refer to the combinations of operands allowed per instruction)
4. Operations (including not only types of operations but also which instructions can access memory and which cannot)
5. Type and size of operands (operands can be addresses, numbers, or even characters)

**Number of Addresses:**

One of the characteristics of the ISA(Industrial Standard Architecture) that shapes the architecture is the number of addresses used in an instruction. Most operations can be divided into binary or unary operations. Binary operations such as addition and multiplication require two input operands whereas the unary operations such as the logical NOT need only a single operand. Most operations produce a single result. There are exceptions, however. For example, the division operation produces two outputs: a quotient and a remainder. Since most operations are binary, we need a total of three addresses: two addresses to specify the two input operands and one to specify where the result should go.

**Three-Address Machines:**

In three-address machines, instructions carry all three addresses explicitly. The RISC processors use three addresses. Table X1 gives some sample instructions of a three-address machine.

In these machines, the C statement

$$A = B + C * D - E + F + A$$

is converted to the following code:

```

mult T,C,D           ; T = C*D
add T,T,B            ; T = B + C*D
sub T,T,E            ; T = B + C*D - E
add T,T,F            ; T = B + C*D - E + F
add A,T,A            ; A = B + C*D - E + F + A

```

Table :T1 Sample three-address machine instructions

Instruction	Semantics
add dest,src1,src2	Adds the two values at src1 and src2 and stores the result in dest $M(\text{dest}) = [\text{src1}] + [\text{src2}]$
sub dest,src1,src2	Subtracts the second source operand at src2 from the first at src1 and stores the result in dest $M(\text{dest}) = [\text{src1}] - [\text{src2}]$
mult dest,src1,src2	Multiplies the two values at src1 and src2 and stores the result in dest $M(\text{dest}) = [\text{src1}] * [\text{src2}]$

We use the notation that each variable represents a memory address that stores the value associated with that variable. This translation from symbol name to the memory address is done by using a symbol table.

As you can see from this code, there is one instruction for each arithmetic operation. Also notice that all instructions, barring the first one, use an address twice. In the middle three instructions, it is the temporary T and in the last one, it is A. This is the motivation for using two addresses, as we show next.

### Two-Address Machines :

In two-address machines, one address doubles as a source and destination. Usually, we use dest to indicate that the address is used for destination. But you should note that this address also supplies one of the source operands. The Pentium is an example processor that uses two addresses. Sample instructions of a two-address machine

On these machines, the C statement

$$A = B + C * D - E + F + A$$

is converted to the following code:

```
load T,C ; T = C
mult T,D ; T = C*D
add T,B ; T = B + C*D
sub T,E ; T = B + C*D - E
add T,F ; T = B + C*D - E + F
add A,T ; A = B + C*D - E + F + A
```

Table :T2 Sample Two-address machine instructions:

Instruction	Semantics
load dest,src	Copies the value at src to dest $M(\text{dest}) = [\text{src}]$
add dest,src	Adds the two values at src and dest and stores the result in dest $M(\text{dest}) = [\text{dest}] + [\text{src}]$
sub dest,src	Subtracts the second source operand at src from the first at dest and stores the result in dest $M(\text{dest}) = [\text{dest}] - [\text{src}]$
mult dest,src	Multiplies the two values at src and dest and stores the result in dest $M(\text{dest}) = [\text{dest}] * [\text{src}]$

Since we use only two addresses, we use a load instruction to first copy the C value into a temporary represented by T. If you look at these six instructions, you will notice that the operand T is common. If we make this our default, then we don't need even two addresses: we can get away with just one address.

### One-Address Machines :

In the early machines, when memory was expensive and slow, a special set of registers was used to provide an input operand as well as to receive the result from the ALU. Because of this, these registers are called the accumulators. In most machines, there is just a single accumulator register. This kind of design, called accumulator machines, makes sense if memory is expensive.

In accumulator machines, most operations are performed on the contents of the accumulator and the operand supplied by the instruction. Thus, instructions for these machines need to specify only the address of a single operand. There is no need to store the result in memory: this reduces the need for larger memory as well as speeds up the computation by reducing the number of memory accesses. A few sample accumulator machine instructions are shown in

Table X3.

In these machines, the C statement

$$A = B + C * D - E + F + A$$

is converted to the following code:

```

load C ; load C into the accumulator
mult D ; accumulator = C*D
add B ; accumulator = C*D+B
sub E ; accumulator = C*D+B-E
add F ; accumulator = C*D+B-E+F
add A ; accumulator = C*D+B-E+F+A
store A ; store the accumulator contents in A

```

Table :T3 Sample ONE-address machine instructions

Instruction	Semantics
load addr	Copies the value at address addr into the accumulator accumulator = [addr]
store addr	Stores the value in the accumulator at the memory address addr M(addr) = accumulator
add addr	Adds the contents of the accumulator and value at address addr accumulator = accumulator + [addr]
sub addr	Subtracts the value at memory address addr from the contents of the accumulator accumulator = accumulator - [addr]
multaddr	Multiplies the contents of the accumulator and value at address addr accumulator = accumulator * [addr]

### Zero-Address Machines :

In zero-address machines, locations of both operands are assumed to be at a default location. These machines use the stack as the source of the input operands and the result goes back into the stack. Stack is a LIFO (last-in-first-out) data structure that all processors support, whether or not they are zero-address machines. As the name implies, the last item placed on the stack is the first item to be taken out of the stack. A good analogy is the stack of trays you find in a cafeteria.

All operations on this type of machine assume that the required input operands are the top two values on the stack. The result of the operation is placed on top of the stack. Table X4 gives some sample instructions for the stack machines.

Table :T4 Sample Zero-address machine instructions

Instruction	Semantics
push addr	Places the value at address addr on top of the stack push([addr])
pop addr	Stores the top value on the stack at memory address addr

	M(addr) = pop
add	Adds the top two values on the stack and pushes the result onto the stack push(pop + pop)
sub	Subtracts the second top value from the top value of the stack and pushes the result onto the stack push(pop - pop)
mult	Multiplies the top two values in the stack and pushes the result onto the stack push(pop * pop)

Notice that the first two instructions are not zero-address instructions. These two are special instructions that use a single address and are used to move data between memory and stack.

All other instructions use the zero-address format. Let's see how the stack machine translates the arithmetic expression we have seen in the previous subsections. In these machines, the C statement

$$A = B + C * D - E + F + A$$

is converted to the following code:

```

push E      ; <E>
push C      ; <C, E>
push D      ; <D, C, E>
mult        ; <C*D, E>
push B      ; <B, C*D, E>
add         ; <B+C*D, E>
sub         ; <B+C*D-E>
push F      ; <F, B+D*C-E>
add         ; <F+B+D*C-E>
push A      ; <A, F+B+D*C-E>
add         ; <A+F+B+D*C-E>
pop A       ; <>

```

On the right, we show the state of the stack after executing each instruction. The top element of the stack is shown on the left. Notice that we pushed E early because we need to subtract it from (B+C\*D).

Stack machines are implemented by making the top portion of the stack internal to the processor. This is referred to as the stack depth. The rest of the stack is placed in memory. Thus, to access the top values that are within the stack depth, we do not have to access the memory. Obviously, we get better performance by increasing the stack depth.

## INSTRUCTION TYPES

Most computer instructions operate on data; however, there are some that do not. Computer manufacturers regularly group instructions into the following categories:

- Data movement
- Arithmetic
- Boolean
- Bit manipulation (shift and rotate)
- I/O



- Transfer of control
- Special purpose

**Data movement instructions** are the most frequently used instructions. Data is moved from memory into registers, from registers to registers, and from registers to memory, and many machines provide different instructions depending on the source and destination. For example, there may be a MOVER instruction that always requires two register operands, whereas a MOVE instruction allows one register and one memory operand.

Some architectures, such as RISC, limit the instructions that can move data to and from memory in an attempt to speed up execution. Many machines have variations of load, store, and move instructions to handle data of different sizes. For example, there may be a LOADB instruction for dealing with bytes and a LOADW instruction for handling words.

**Arithmetic operations** include those instructions that use integers and floating point numbers. Many instruction sets provide different arithmetic instructions for various data sizes. As with the data movement instructions, there are sometimes different instructions for providing various combinations of register and memory accesses in different addressing modes.

**Boolean logic** instructions perform Boolean operations, much in the same way that arithmetic operations work. There are typically instructions for performing AND, NOT, and often OR and XOR operations.

**Bit manipulation** instructions are used for setting and resetting individual bits (or sometimes groups of bits) within a given data word. These include both arithmetic and logical shift instructions and rotate instructions, both to the left and to the right. Logical shift instructions simply shift bits to either the left or the right by a specified amount, shifting in zeros from the opposite end. Arithmetic shift instructions, commonly used to multiply or divide by 2, do not shift the leftmost bit, because this represents the sign of the number. On a right arithmetic shift, the sign bit is replicated into the bit position to its right. On a left arithmetic shift, values are shifted left, zeros are shifted in, but the sign bit is never moved. Rotate instructions are simply shift instructions that shift in the bits that are shifted out. For example, on a rotate left 1 bit, the leftmost bit is shifted out and rotated around to become the rightmost bit.

**I/O instructions** vary greatly from architecture to architecture. The basic schemes for handling I/O are programmed I/O, interrupt-driven I/O, and DMA devices. These are covered in more detail in Chapter 5.

**Control instructions** include branches, skips, and procedure calls. Branching can be unconditional or conditional. Skip instructions are basically branch instructions with implied addresses. Because no operand is required, skip instructions often use bits of the address field to specify different situations (recall the Skipcond instruction used by MARIE). Procedure calls are special branch instructions that automatically save the return address. Different machines use different methods to save this address. Some store the address at a specific location in memory, others store it in a register, while still others push the return address on a stack. We have already seen that stacks can be used for other purposes.

**Special purpose instructions** include those used for string processing, high level language support, protection, flag control, and cache management. Most architectures provide instructions for string processing, including string manipulation and searching.

## Addressing Modes

We have examined the types of **operands** and **operations** that may be specified by **machine instructions**. Now we have to see how is the address of an operand specified, and how are the **bits** of an instruction organized to define the **operand addresses** and operation of that instruction.

**Addressing Modes:** The most common addressing techniques are

- Immediate
- Direct
- Indirect
- Register
- Register Indirect
- Displacement
- Stack

All computer architectures provide more than one of these addressing modes. The question arises as to how the control unit can determine which addressing mode is being used in a particular instruction. Several approaches are used. Often, different opcodes will use different addressing modes. Also, one or more bits in the instruction format can be used as a mode field. The value of the mode field determines which addressing mode is to be used.

What is the interpretation of *effective address*. In a system without virtual memory, the effective address will be either a main memory address or a register. In a virtual memory system, the effective address is a virtual address or a register. The actual mapping to a physical address is a function of the paging mechanism and is invisible to the programmer.

To explain the addressing modes, we use the following notation:

<b>A</b>	=	contents of an address field in the instruction that refers to a memory
<b>R</b>	=	contents of an address field in the instruction that refers to a register
<b>EA</b>	=	actual (effective) address of the location containing the referenced operand
<b>(X)</b>	=	contents of location X

### ***Immediate Addressing:***

The simplest form of addressing is immediate addressing, in which the operand is actually present in the instruction:

$$\text{OPERAND} = \text{A}$$

This mode can be used to define and use constants or set initial values of variables. The advantage of immediate addressing is that no memory reference other than the instruction fetch is required to obtain the operand. The disadvantage is that the size of the number is restricted to the size of the address field, which, in most instruction sets, is small compared with the word length.



**Figure 4.1: Immediate Addressing Mod**

The instruction format for Immediate Addressing Mode is shown in the Figure 4.1.

**Direct Addressing:**

A very simple form of addressing is direct addressing, in which the address field contains the effective address of the operand:

$$EA = A$$

It requires only one memory reference and no special calculation.

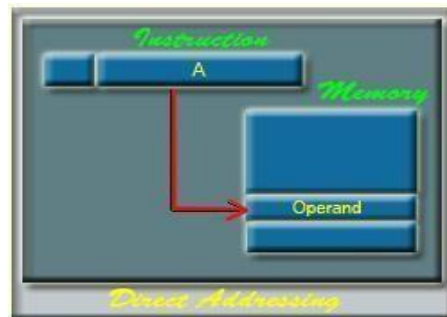

Figure 4.2: Direct Addressing Mode

**Indirect Addressing:**

With direct addressing, the length of the address field is usually less than the word length, thus limiting the address range. One solution is to have the address field refer to the address of a word in memory, which in turn contains a full-length address of the operand. This is known as indirect addressing:

$$EA = (A)$$

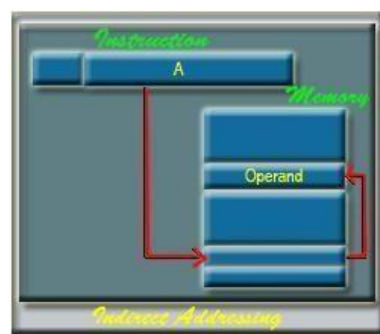

Figure 4.3: Indirect Addressing Mode

**Register Addressing:**

Register addressing is similar to direct addressing. The only difference is that the address field refers to a register rather than a main memory address:

$$EA = R$$

The advantages of register addressing are that only a small address field is needed in the instruction and no memory reference is required. The disadvantage of register addressing is that the address space is very limited.

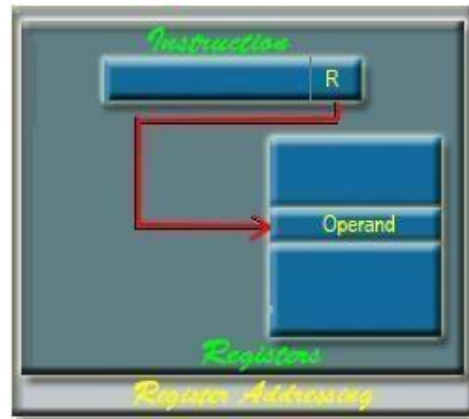

**Figure 4.4:** Register Addressing Mode.

The exact register location of the operand in case of Register Addressing Mode is shown in the Figure 34.4. Here, 'R' indicates a register where the operand is present.

#### **Register Indirect Addressing:**

Register indirect addressing is similar to indirect addressing, except that the address field refers to a register instead of a memory location. It requires only one memory reference and no special calculation.

$$EA = (R)$$

Register indirect addressing uses one less memory reference than indirect addressing. Because, the first information is available in a register which is nothing but a memory address. From that memory location, we use to get the data or information. In general, register access is much more faster than the memory access.

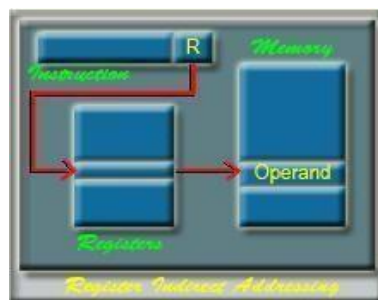

#### **Displacement Addressing:**

A very powerful mode of addressing combines the capabilities of direct addressing and register indirect addressing, which is broadly categorized as displacement addressing:

$$EA = A + (R)$$

Displacement addressing requires that the instruction have two address fields, at least one of which is explicit. The value contained in one address field (value = A) is used directly. The other address field, or an implicit reference based on opcode, refers to a register whose contents are added to A to produce the effective address. The general format of Displacement Addressing is shown in the Figure 4.6.

Three of the most common use of displacement addressing are:

- Relative addressing
- Base-register addressing
- Indexing

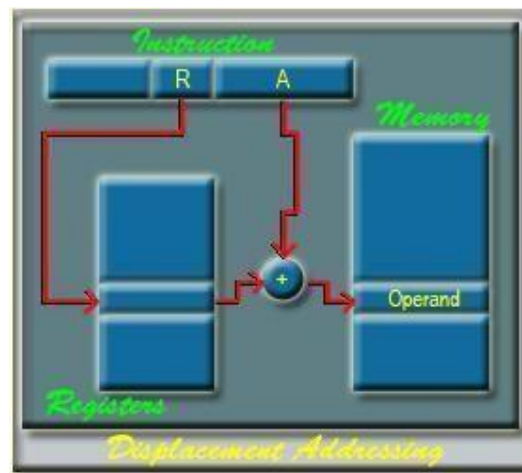

**Figure 4.6:** Displacement Addressing

**Relative Addressing:**

For relative addressing, the implicitly referenced register is the program counter (PC). That is, the current instruction address is added to the address field to produce the EA. Thus, the effective address is a displacement relative to the address of the instruction.

**Base-Register Addressing:**

The reference register contains a memory address, and the address field contains a displacement from that address. The register reference may be explicit or implicit. In some implementation, a single segment/base register is employed and is used implicitly. In others, the programmer may choose a register to hold the base address of a segment, and the instruction must reference it explicitly.

**Indexing:**

The address field references a main memory address, and the reference register contains a positive displacement from that address. In this case also the register reference is sometimes explicit and sometimes implicit.

Generally index register are used for iterative tasks, it is typical that there is a need to increment or decrement the index register after each reference to it. Because this is such a common operation, some system will automatically do this as part of the same instruction cycle. This is known as auto-indexing. We may get two types of auto-indexing: -one is auto-incrementing and the other one is -auto-decrementing.

If certain registers are devoted exclusively to indexing, then auto-indexing can be invoked implicitly and automatically. If general purpose register are used, the auto index operation may need to be signaled by a bit in the instruction.

Auto-indexing using *increment* can be depicted as follows:

$$\begin{aligned} EA &= A + (R) \\ R &= (R) + 1 \end{aligned}$$

Auto-indexing using *decrement* can be depicted as follows:

$$\begin{aligned}EA &= A + (R) \\ R &= (R) - 1\end{aligned}$$

In some machines, both *indirect addressing* and *indexing* are provided, and it is possible to employ both in the same instruction. There are two possibilities: The indexing is performed either before or after the indirection.

If indexing is performed after the indirection, it is termed post indexing

$$EA = (A) + (R)$$

First, the contents of the address field are used to access a memory location containing an address. This address is then indexed by the register value.

With pre indexing, the indexing is performed before the indirection:

$$EA = (A + (R))$$

An address is calculated, the calculated address contains not the operand, but the address of the operand.

***Stack Addressing:***

A stack is a linear array or list of locations. It is sometimes referred to as a pushdown list or last-in- first-out queue. A stack is a reserved block of locations. Items are appended to the top of the stack so that, at any given time, the block is partially filled. Associated with the stack is a pointer whose value is the address of the top of the stack. The stack pointer is maintained in a register. Thus, references to stack locations in memory are in fact register indirect addresses.

The stack mode of addressing is a form of implied addressing. The machine instructions need not include a memory reference but implicitly operate on the top of the stack.

## UNIT 4

**Syllabus:**

Memory Organization: Semiconductor memory technologies, hierarchy, Interleaving, Main Memory-RAM and ROM chips, Address map, Associative memory-Hardware organization. Match logic. Cache memory-size vs. block size, Mapping functions-Associate, Direct, Set Associative mapping. Replacement algorithms, write policies. Auxiliary memory-Magnetic tapes etc

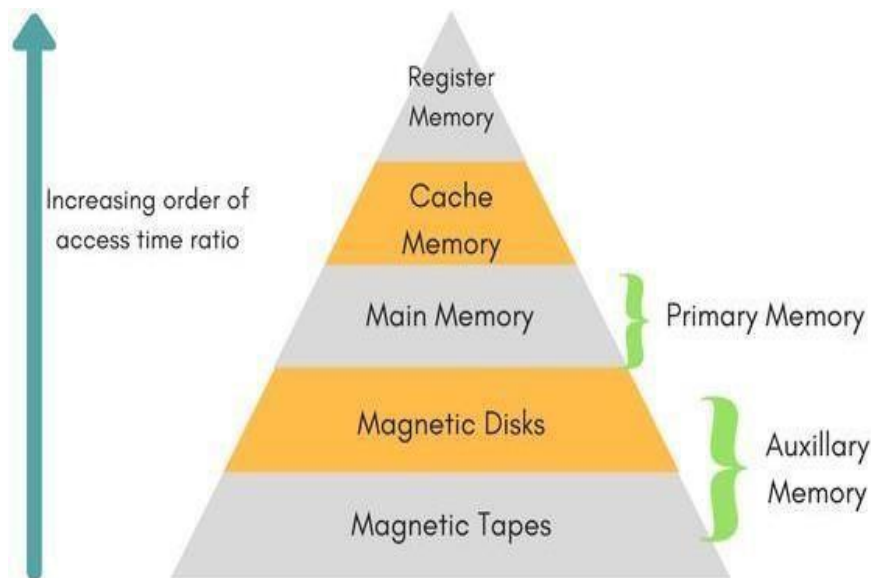
**Memory Hierarchy**

The total memory capacity of a computer can be visualized by hierarchy of components. The memory hierarchy system consists of all storage devices contained in a computer system from the slow Auxiliary Memory to fast Main Memory and to smaller Cache memory.

**Auxillary memory** access time is generally **1000 times** that of the main memory, hence it is at the bottom of the hierarchy.

The **main memory** occupies the central position because it is equipped to communicate directly with the CPU and with auxiliary memory devices through Input/output processor (I/O).

When the program not residing in main memory is needed by the CPU, they are brought in from auxiliary memory. Programs not currently needed in main memory are transferred into auxiliary memory to provide space in main memory for other programs that are currently in use.

The **cache memory** is used to store program data which is currently being executed in the CPU. Approximate access time ratio between cache memory and main memory is about **1 to 7~10**

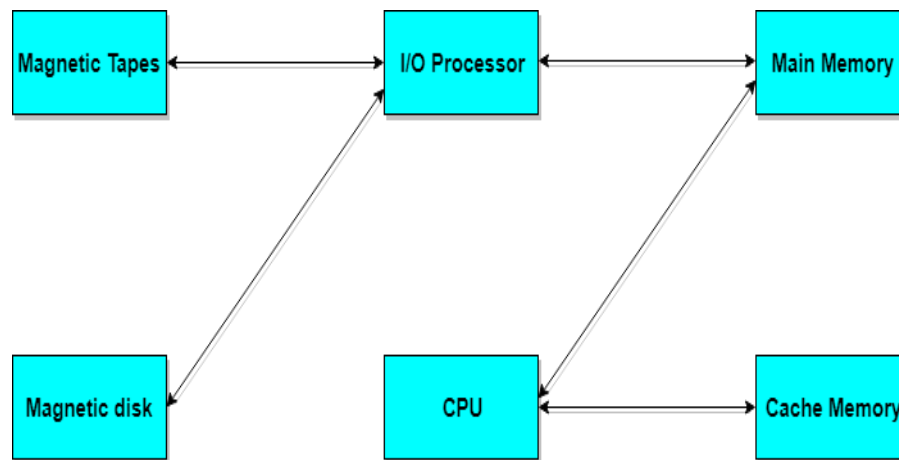

### Memory Access Methods

Each memory type, is a collection of numerous memory locations. To access data from any memory, first it must be located and then the data is read from the memory location. Following are the methods to access information from memory locations:

1. **Random Access:** Main memories are random access memories, in which each memory location has a unique address. Using this unique address any memory location can be reached in the same amount of time in any order.
2. **Sequential Access:** This methods allows memory access in a sequence or in order.
3. **Direct Access:** In this mode, information is stored in tracks, with each track having a separate read/write head.

### Main Memory

The memory unit that communicates directly within the CPU, Auxillary memory and Cache memory, is called main memory. It is the central storage unit of the computer system. It is a large and fast memory used to store data during computer operations. Main memory is made up of **RAM** and **ROM**, with RAM integrated circuit chips holding the major share.

- **RAM: Random Access Memory**
  - **DRAM:** Dynamic RAM, is made of capacitors and transistors, and must be refreshed every 10~100 ms. It is slower and cheaper than SRAM.
  - **SRAM:** Static RAM, has a six transistor circuit in each cell and retains data, until powered off.
  - **NVRAM:** Non-Volatile RAM, retains its data, even when turned off. Example: Flash memory.



- ROM: Read Only Memory, is non-volatile and is more like a permanent storage for information. It also stores the **bootstrap loader** program, to load and start the operating system when computer is turned on. **PROM**(Programmable ROM), **EPROM**(Erasable PROM) and **EEPROM**(Electrically Erasable PROM) are some commonly used ROMs.

### Memory Address map:

- The addressing of memory can establish by means of a table that specifies the memory address assigned to each chip.
- The table, called a **memory address map**, is a pictorial representation of assigned address space for each chip in the system, shown in the table.
- To demonstrate with a particular example, assume that a computer system needs 512 bytes of RAM and 512 bytes of ROM.
- The RAM and ROM chips to be used specified in figures.

Component	Hexa address	Address bus									
		10	9	8	7	6	5	4	3	2	1
RAM 1	0000 - 007F	0	0	0	x	x	x	x	x	x	x
RAM 2	0080 - 00FF	0	0	1	x	x	x	x	x	x	x
RAM 3	0100 - 017F	0	1	0	x	x	x	x	x	x	x
RAM 4	0180 - 01FF	0	1	1	x	x	x	x	x	x	x
ROM	0200 - 03FF	1	x	x	x	x	x	x	x	x	x

- The component column specifies whether a RAM or a ROM chip used.
- Moreover, The hexadecimal address column assigns a range of hexadecimal equivalent addresses for each chip.
- The address bus lines listed in the third column.
- Although there 16 lines in the address bus, the table shows only 10 lines because the other 6 not used in this example and assumed to be zero.
- The small x's under the address bus lines designate those lines that must connect to the address inputs in each chip.
- Moreover, The RAM chips have 128 bytes and need seven address lines. The ROM chip has 512 bytes and needs 9 address lines.
- The x's always assigned to the low-order bus lines: lines 1 through 7 for the RAM. And lines 1 through 9 for the ROM.
- It is now necessary to distinguish between four RAM chips by assigning to each a different address. For this particular example, we choose bus lines 8 and 9 to represent four distinct binary combinations.
- Also, The table clearly shows that the nine low-order bus lines constitute a memory space for RAM equal to  $2^9 = 512$  bytes.
- The distinction between a RAM and ROM address done with another bus line. Here we choose line 10 for this purpose.
- When line 10 0, the CPU selects a RAM, and when this line equal to 1, it selects the ROM.

### Auxiliary Memory

Devices that provide backup storage are called auxiliary memory. **For example:** Magnetic disks and tapes are commonly used auxiliary devices. Other devices used as

auxiliary memory are magnetic drums, magnetic bubble memory and optical disks.

It is not directly accessible to the CPU, and is accessed using the Input/Output channels.

### Cache Memory

The data or contents of the main memory that are used again and again by CPU, are stored in the cache memory so that we can easily access that data in shorter time.

Whenever the CPU needs to access memory, it first checks the cache memory. If the data is not found in cache memory then the CPU moves onto the main memory. It also transfers block of recent data into the cache and keeps on deleting the old data in cache to accommodate the new one.

### Hit Ratio

The performance of cache memory is measured in terms of a quantity called **hit ratio**. When the CPU refers to memory and finds the word in cache it is said to produce a **hit**. If the word is not found in cache, it is in main memory then it counts as a **miss**.

The ratio of the number of hits to the total CPU references to memory is called hit ratio.

$$\text{Hit Ratio} = \text{Hit}/(\text{Hit} + \text{Miss})$$

### Associative Memory

It is also known as **content addressable memory (CAM)**. It is a memory chip in which each bit position can be compared. In this the content is compared in each bit cell which allows very fast table lookup. Since the entire chip can be compared, contents are randomly stored without considering addressing scheme. These chips have less storage capacity than regular memory chips.

### Memory Mapping and Concept of Virtual Memory

The transformation of data from main memory to cache memory is called mapping. There are 3 main types of mapping:

- Associative Mapping
- Direct Mapping
- Set Associative Mapping

### Associative Mapping

The associative memory stores both address and data. The address value of 15 bits is 5 digit octal numbers and data is of 12 bits word in 4 digit octal number. A CPU address of 15 bits is placed in **argument register** and the associative memory is searched for matching address.

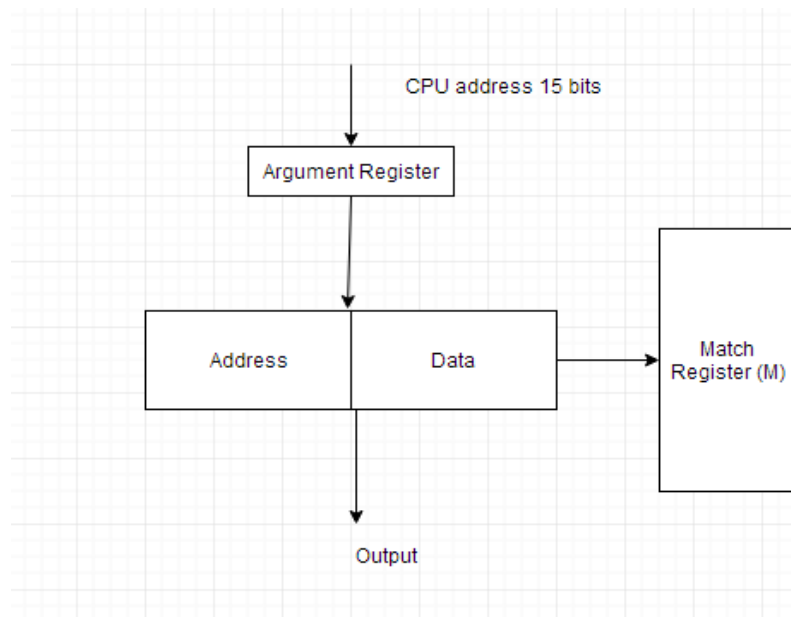

### Direct Mapping

The CPU address of 15 bits is divided into 2 fields. In this the 9 least significant bits constitute the **index** field and the remaining 6 bits constitute the **tag** field. The number of bits in index field is equal to the number of address bits required to access cache memory.

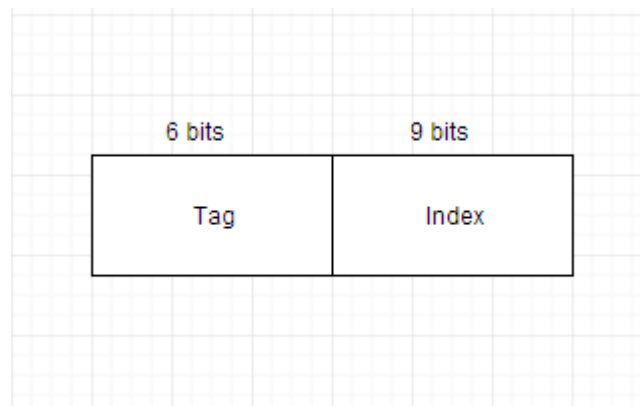

### Set Associative Mapping

The disadvantage of direct mapping is that two words with same index address can't reside in cache memory at the same time. This problem can be overcome by set associative mapping.

In this we can store two or more words of memory under the same index address. Each data word is stored together with its tag and this forms a set.

Tag	Data	Address

### Replacement Algorithms

Data is continuously replaced with new data in the cache memory using replacement algorithms. Following are the 2 replacement algorithms used:

- FIFO - First in First out. Oldest item is replaced with the latest item.
- LRU - Least Recently Used. Item which is least recently used by CPU is removed.

### Writing in to cache and cache Initialization:

The benefit of write-through to main memory is that it simplifies the design of the computer system. With write-through, the main memory always has an up-to-date copy of the line. So when a read is done, main memory can always reply with the requested data.

If write-back is used, sometimes the up-to-date data is in a processor cache, and sometimes it is in main memory. If the data is in a processor cache, then that processor must stop main memory from replying to the read request, because the main memory might have a stale copy of the data. This is more complicated than write-through.

Also, write-through can simplify the cache coherency protocol because it doesn't need the *Modify* state. The *Modify* state records that the cache must write back the cache line before it invalidates or evicts the line. In write-through a cache line can always be invalidated without writing back since memory already has an up-to-date copy of the line.

### Cache Coherence:

In a shared memory multiprocessor with a separate cache memory for each processor, it is possible to have many copies of any one instruction operand: one copy in the main memory and one in each cache memory. When one copy of an operand is changed, the other copies of the operand must be changed also. Cache coherence is the discipline that ensures that changes in the values of shared operands are propagated throughout the system in a timely fashion.

### Virtual Memory

Virtual memory is the separation of logical memory from physical memory. This separation provides large virtual memory for programmers when only small physical memory is available.

Virtual memory is used to give programmers the illusion that they have a very large memory even though the computer has a small main memory. It makes the task of programming easier because the programmer no longer needs to worry about the amount of physical memory available.

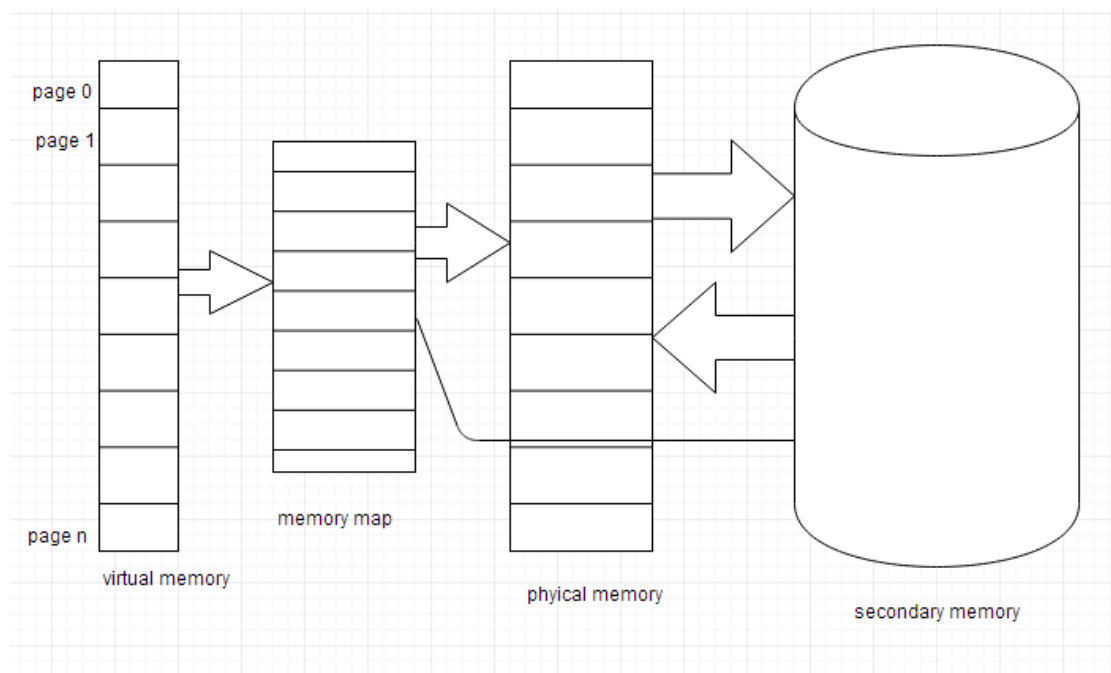

### Address mapping using pages:

- The table implementation of the address mapping is simplified if the information in the address space. And the memory space is each divided into groups of fixed size.
- Moreover, The physical memory is broken down into groups of equal size called blocks, which may range from 64 to 4096 words each.
- The term page refers to groups of address space of the same size.
- Also, Consider a computer with an address space of 8K and a memory space of 4K.
- If we split each into groups of 1K words we obtain eight pages and four blocks as shown in the figure.
- At any given time, up to four pages of address space may reside in main memory in any one of the four blocks.

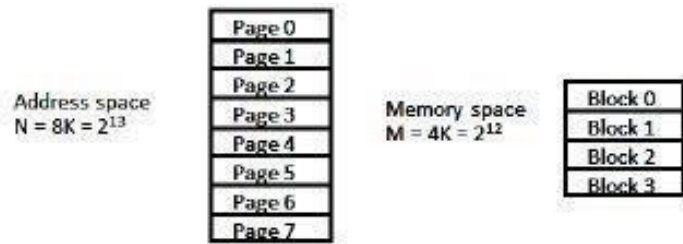
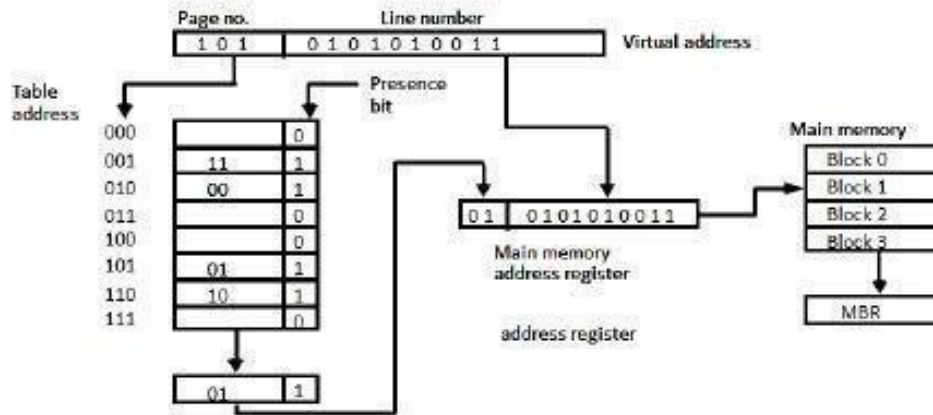

Figure Address and Memory space split into group of 1K words



**Associative memory page table:**

The implementation of the page table is vital to the efficiency of the virtual memory technique, for each memory reference must also include a reference to the page table. The fastest solution is a set of dedicated registers to hold the page table but this method is impractical for large page tables because of the expense. But keeping the page table in main memory could cause intolerable delays because even only one memory access for the page table involves a slowdown of 100 percent and large page tables can require more than one memory access. The solution is to augment the page table with special high-speed memory made up of associative registers or translation look aside buffers (TLBs) which are called ASSOCIATIVE MEMORY.

**Page replacement**

The advantage of virtual memory is that processes can be using more memory than exists in the machine; when memory is accessed that is not present (a **page fault**), it must be paged in (sometimes referred to as being "swapped in", although some people reserve "swapped in" to refer to bringing in an entire address space).

Swapping in pages is very expensive (it requires using the disk), so we'd like to avoid page faults as much as possible. The algorithm that we use to choose which pages to evict to make space for the new page can have a large impact on the number of page faults that occur.

## UNIT 5

### Syllabus:

Input –Output Organization: Peripheral devices, Input-output subsystems, I/O device interface, I/O Processor, I/O transfers–Program controlled, Interrupt driven, and DMA, interrupts and exceptions. I/O device interfaces – SCII, USB Pipelining and Vector Processing: Basic concepts, Instruction level Parallelism Throughput and Speedup, Pipeline hazards.

### Introduction:

The I/O subsystem of a computer provides an efficient mode of communication between the central system and the outside environment. It handles all the input-output operations of the computer system.

### Peripheral Devices

Input or output devices that are connected to computer are called **peripheral devices**. These devices are designed to read information into or out of the memory unit upon command from the CPU and are considered to be the part of computer system. These devices are also called **peripherals**.

For example: *Keyboards, display units and printers* are common peripheral devices.

There are three types of peripherals:

1. **Input peripherals** : Allows user input, from the outside world to the computer.  
Example: Keyboard, Mouse etc.
2. **Output peripherals**: Allows information output, from the computer to the outside world. Example: Printer, Monitor etc
3. **Input-Output peripherals**: Allows both input(from outside world to computer) as well as, output(from computer to the outside world). Example: Touch screen etc.

### Interfaces

Interface is a shared boundary between two separate components of the computer system which can be used to attach two or more components to the system for communication purposes.

There are two types of interface:

1. CPU Interface
2. I/O Interface

Let's understand the I/O Interface in details,

## Input-Output Interface

Peripherals connected to a computer need special communication links for interfacing with CPU. In computer system, there are special hardware components between the CPU and peripherals to control or manage the input-output transfers. These components are called **input-output interface units** because they provide communication links between processor bus and peripherals. They provide a method for transferring information between internal system and input-output devices.

### Asynchronous Data Transfer

We know that, the internal operations in individual unit of digital system are synchronized by means of clock pulse, means clock pulse is given to all registers within a unit, and all data transfer among internal registers occur simultaneously during occurrence of clock pulse. Now, suppose any two units of digital system are designed independently such as CPU and I/O interface.

And if the registers in the interface(I/O interface) share a common clock with CPU registers, then transfer between the two units is said to be synchronous. But in most cases, the internal timing in each unit is independent from each other in such a way that each uses its own private clock for its internal registers. In that case, the two units are said to be asynchronous to each other, and if data transfer occur between them this data transfer is said to be **Asynchronous Data Transfer**.

But, the Asynchronous Data Transfer between two independent units requires that control signals be transmitted between the communicating units so that the time can be indicated at which they send data.

This asynchronous way of data transfer can be achieved by two methods:

1. One way is by means of strobe pulse which is supplied by one of the units to other unit. When transfer has to occur. This method is known as “**Strobe Control**”.
2. Another method commonly used is to accompany each data item being transferred with a control signal that indicates the presence of data in the bus. The unit receiving the data item responds with another signal to acknowledge receipt of the data. This method of data transfer between two independent units is said to be “**Handshaking**”.

The strobe pulse and handshaking method of asynchronous data transfer are not restricted to I/O transfer. In fact, they are used extensively on numerous occasion requiring transfer of data between two independent units. So, here we consider the transmitting unit as source and receiving unit as destination.

As an example: The CPU, is the source during an output or write transfer and is the destination unit during input or read transfer.

And thus, the sequence of control during an asynchronous transfer depends on whether the transfer is initiated by the source or by the destination.

So, while discussing each way of data transfer asynchronously we see the sequence of control in both terms when it is initiated by source or when it is initiated by destination. In this way, each way of data transfer, can be further divided into parts, source initiated and destination initiated.



We can also specify, asynchronous transfer between two independent units by means of a timing diagram that shows the timing relationship that exists between the control and the data buses.

Now, we will discuss each method of asynchronous data transfer in detail one by one.

### 1. **Strobe Control:**

The Strobe Control method of asynchronous data transfer employs a single control line to time each transfer. This control line is also known as strobe and it may be achieved either by source or destination, depending on which initiates transfer.

#### **Source initiated strobe for data transfer:**

The block diagram and timing diagram of strobe initiated by source unit is shown in figure below:

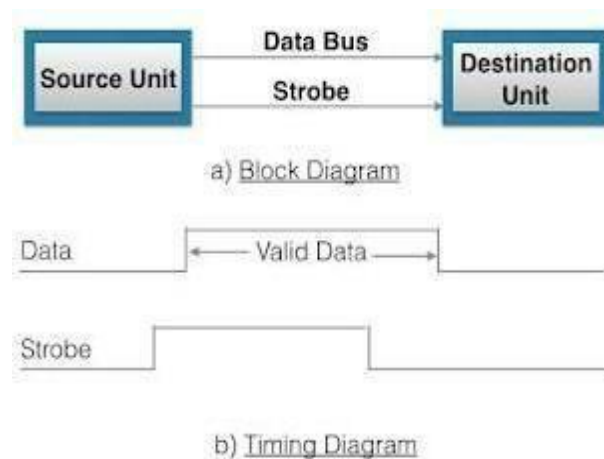

In block diagram we see that strobe is initiated by source, and as shown in timing diagram, the source unit first places the data on the data bus. After a brief delay to ensure that the data settle to a steady value, the source activates a strobe pulse. The information on data bus and strobe control signal remain in the active state for a sufficient period of time to allow the destination unit to receive the data. Actually, the destination unit, uses a falling edge of strobe control to transfer the contents of data bus to one of its internal registers. The source removes the data from the data bus after it disables its strobe pulse. New valid data will be available only after the strobe is enabled again.

#### **Destination-initiated strobe for data transfer:**

The block diagram and timing diagram of strobe initiated by destination is shown in figure below:

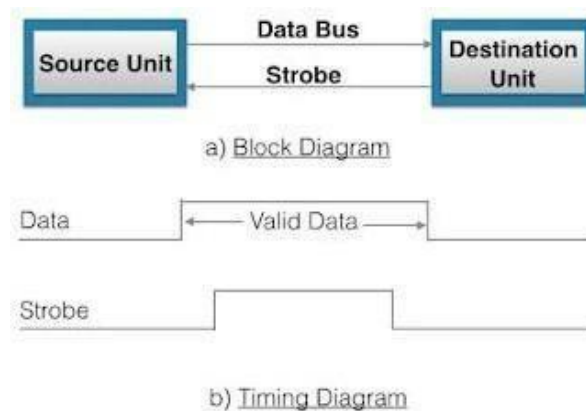

In block diagram, we see that, the strobe initiated by destination, and as shown in timing diagram, the destination unit first activates the strobe pulse, informing the source to provide the data. The source unit responds by placing the requested binary information on the data bus. The data must be valid and remain in the bus long enough for the destination unit to accept it. The falling edge of strobe pulse can be used again to trigger a destination register. The destination unit then disables the strobe. And source removes the data from data bus after a predetermined time interval.

Now, actually in computer, in the first case means in strobe initiated by source - the strobe may be a memory-write control signal from the CPU to a memory unit. The source, CPU, places the word on the data bus and informs the memory unit, which is the destination, that this is a write operation.

And in the second case i.e, in the strobe initiated by destination - the strobe may be a memory read control from the CPU to a memory unit. The destination, the CPU, initiates the read operation to inform the memory, which is a source unit, to place selected word into the data bus.

## 2. Handshaking:

The disadvantage of strobe method is that source unit that initiates the transfer has no way of knowing whether the destination has actually received the data that was placed in the bus. Similarly, a destination unit that initiates the transfer has no way of knowing whether the source unit, has actually placed data on the bus.

This problem can be solved by handshaking method.

Hand shaking method introduce a second control signal line that provides a replay to the unit that initiates the transfer.

In it, one control line is in the same direction as the data flow in the bus from the source to destination. It is used by source unit to inform the destination unit whether there are valid data in the bus. The other control line is in the other direction from destination to the source. It is used by the destination unit to inform the source whether it can accept data. And in it also, sequence of control depends on unit that initiate transfer. Means sequence of control depends whether transfer is initiated by source and destination. Sequence of control in both of them are described below:

**Source initiated Handshaking:**

The source initiated transfer using handshaking lines is shown in figure below:

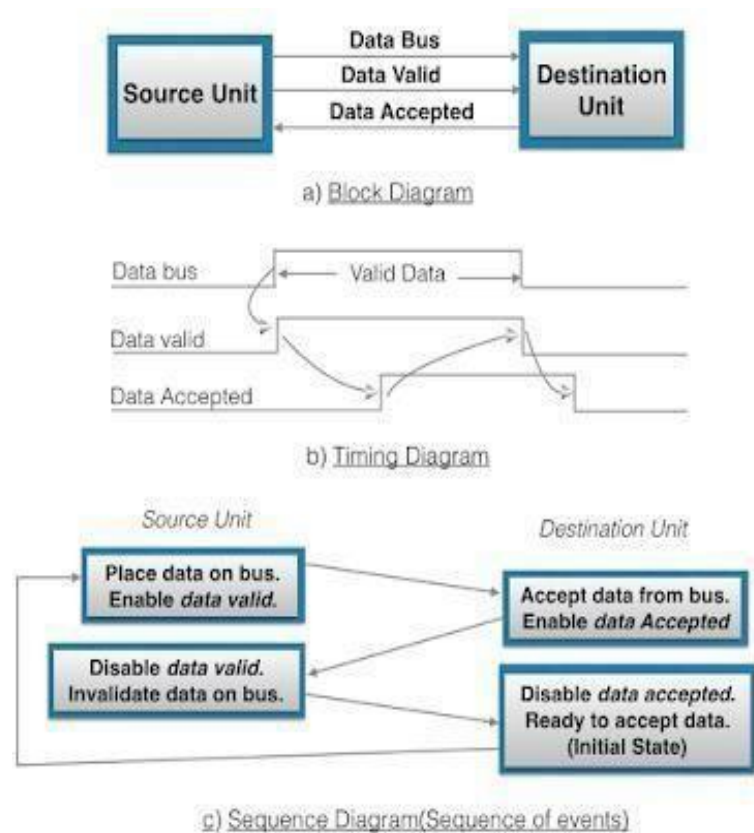

In its block diagram, we see that two handshaking lines are "data valid", which is generated by the source unit, and "data accepted", generated by the destination unit.

The timing diagram shows the timing relationship of exchange of signals between the two units. Means as shown in its timing diagram, the source initiates a transfer by placing data on the bus and enabling its data valid signal. The data accepted signal is then activated by destination unit after it accepts the data from the bus. The source unit then disables its data valid signal which invalidates the data on the bus. After this, the destination unit disables its data accepted signal and the system goes into initial state. The source unit does not send the next data item until after the destination unit shows its readiness to accept new data by disabling the data accepted signal.

This sequence of events described in its sequence diagram, which shows the above sequence in which the system is present, at any given time.

**Destination initiated handshaking:**

The destination initiated transfer using handshaking lines is shown in figure below:

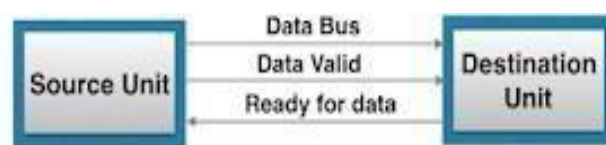

a) Block Diagram

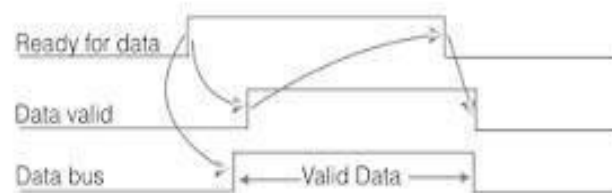

b) Timing Diagram

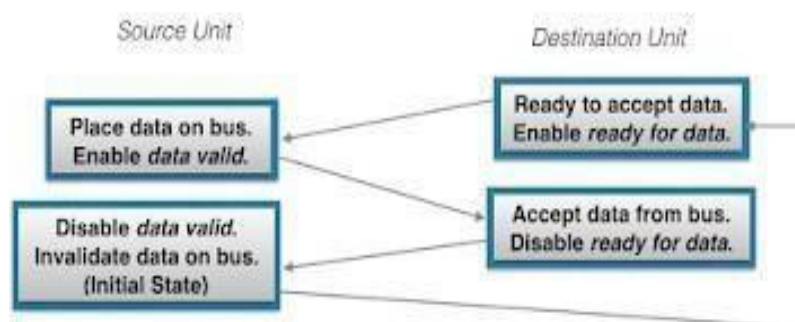

c) Sequence Diagram(sequence of events)

In its block diagram, we see that the two handshaking lines are "data valid", generated by the source unit, and "ready for data" generated by destination unit. Note that the name of signal data accepted generated by destination unit has been changed to ready for data to reflect its new meaning.

In it, transfer is initiated by destination, so source unit does not place data on data bus until it receives ready for data signal from destination unit. After that, handshaking process is some as that of source initiated.

The sequence of event in it are shown in its sequence diagram and timing relationship between signals is shown in its timing diagram.

Thus, here we can say that, sequence of events in both cases would be identical. If we consider ready for data signal as the complement of data accept. Means, the only difference between source and destination initiated transfer is in their choice of initial state.

### Modes of I/O Data Transfer

Data transfer between the central unit and I/O devices can be handled in generally three types of modes which are given below:

1. Programmed I/O
2. Interrupt Initiated I/O
3. Direct Memory Access

### Programmed I/O

Programmed I/O instructions are the result of I/O instructions written in computer program. Each data item transfer is initiated by the instruction in the program.

Usually the program controls data transfer to and from CPU and peripheral. Transferring data under programmed I/O requires constant monitoring of the peripherals by the CPU.

### Interrupt Initiated I/O

In the programmed I/O method the CPU stays in the program loop until the I/O unit indicates that it is ready for data transfer. This is time consuming process because it keeps the processor busy needlessly.

This problem can be overcome by using **interrupt initiated I/O**. In this when the interface determines that the peripheral is ready for data transfer, it generates an interrupt. After receiving the interrupt signal, the CPU stops the task which it is processing and service the I/O transfer and then returns back to its previous processing task.

### Direct Memory Access

Removing the CPU from the path and letting the peripheral device manage the memory buses directly would improve the speed of transfer. This technique is known as **DMA**.

In this, the interface transfer data to and from the memory through memory bus. A DMA controller manages to transfer data between peripherals and memory unit.

Many hardware systems use DMA such as disk drive controllers, graphic cards, network cards and sound cards etc. It is also used for intra chip data transfer in multicore processors. In DMA, CPU would initiate the transfer, do other operations while the transfer is in progress and receive an interrupt from the DMA controller when the transfer has been completed.

### Priority Interrupt

A priority interrupt is a system which decides the priority at which various devices, which generates the interrupt signal at the same time, will be serviced by the CPU. The system has authority to decide which conditions are allowed to interrupt the CPU, while some other interrupt is being serviced. Generally, devices with high speed transfer such as *magnetic disks* are given high priority and slow devices such as *keyboards* are given low priority.

When two or more devices interrupt the computer simultaneously, the computer services the device with the higher priority first.

## DIRECT MEMORY ACCESS

Block of data transfer from high speed devices, Drum, Disk, Tape

### CPU bus signals for DMA transfer

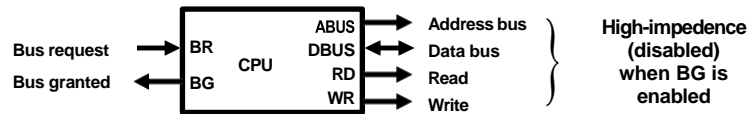

### Block diagram of DMA controller

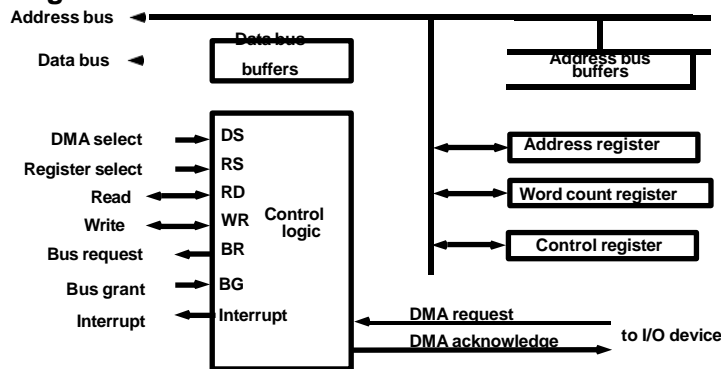

- \* DMA controller - Interface which allows I/O transfer directly between Memory and Device, freeing CPU for other tasks
- \* CPU initializes DMA Controller by sending memory address and the block size(number of words)

## DMA TRANSFER

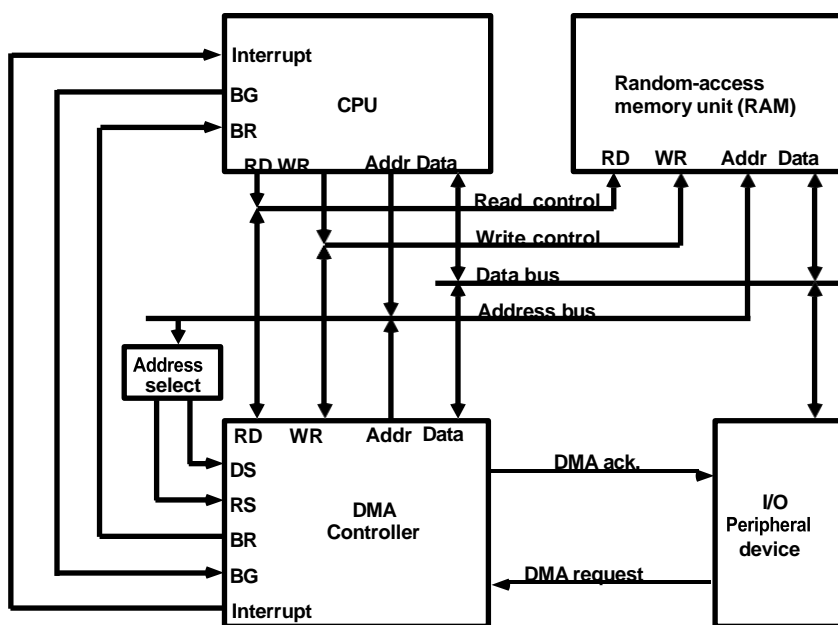

## Input/output Processor

An input-output processor (IOP) is a processor with direct memory access capability. In this, the computer system is divided into a memory unit and number of processors.

Each IOP controls and manage the input-output tasks. The IOP is similar to CPU except that it handles only the details of I/O processing. The IOP can fetch and execute its own instructions. These IOP instructions are designed to manage I/O transfers only.

### Block Diagram Of I/O Processor:

Below is a block diagram of a computer along with various I/O Processors. The memory unit occupies the central position and can communicate with each processor.

The CPU processes the data required for solving the computational tasks. The IOP provides a path for transfer of data between peripherals and memory. The CPU assigns the task of initiating the I/O program.

The IOP operates independent from CPU and transfer data between peripherals and memory.

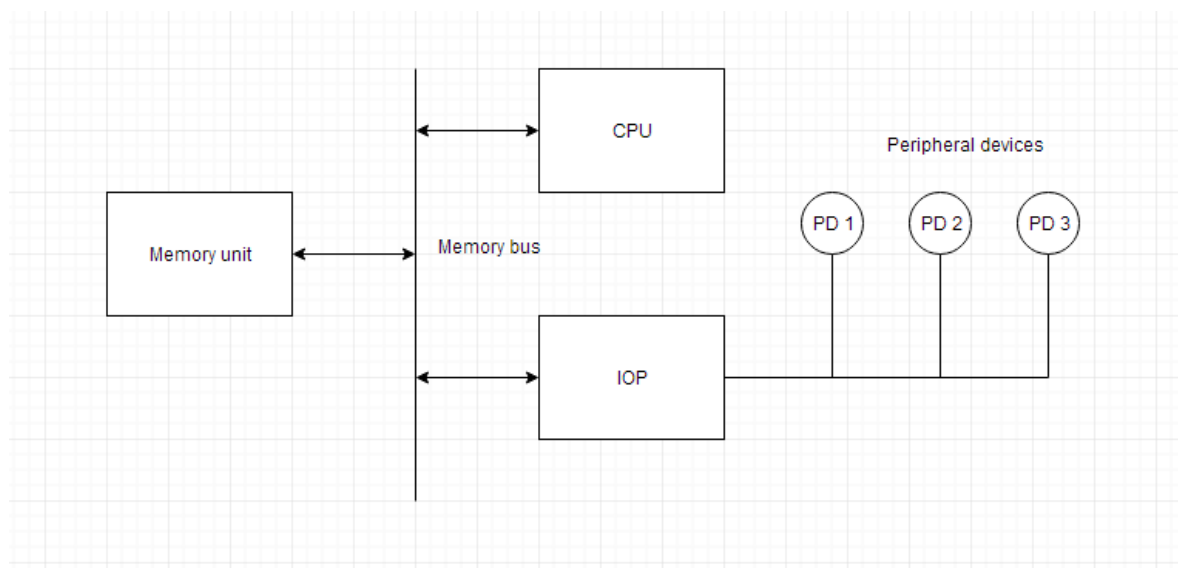

The communication between the IOP and the devices is similar to the program control method of transfer. And the communication with the memory is similar to the direct memory access method.

In large scale computers, each processor is independent of other processors and any processor can initiate the operation.

The CPU can act as master and the IOP act as slave processor. The CPU assigns the task of initiating operations but it is the IOP, who executes the instructions, and not the CPU. CPU instructions provide operations to start an I/O transfer. The IOP asks for CPU through interrupt.

Instructions that are read from memory by an IOP are also called *commands* to distinguish them from instructions that are read by CPU. Commands are prepared by programmers and are stored in memory. Command words make the program for IOP. CPU informs the IOP where to find the commands in memory.

## Pipelining and vector processing

### Parallel processing

Execution of Concurrent Events in the computing process to achieve faster Computational Speed

### Levels of Parallel Processing

- Job or Program level
- Task or Procedure level
- Inter-Instruction level
- Intra-Instruction level

### PARALLEL COMPUTERS

Architectural Classification

Flynn's classification

- » Based on the multiplicity of *Instruction Streams* and *Data Streams*
- » Instruction Stream  
Sequence of Instructions read from memory
- » Data Stream  
Operations performed on the data in the processor

### What is Pipelining?

Pipelining is the process of accumulating instruction from the processor through a pipeline. It allows storing and executing instructions in an orderly process. It is also known as **pipeline processing**.

Pipelining is a technique where multiple instructions are overlapped during execution. Pipeline is divided into stages and these stages are connected with one another to form a pipe like structure. Instructions enter from one end and exit from another end.

Pipelining increases the overall instruction throughput.

In pipeline system, each segment consists of an input register followed by a combinational circuit. The register is used to hold data and combinational circuit performs operations on it. The output of combinational circuit is applied to the input register of the next segment.



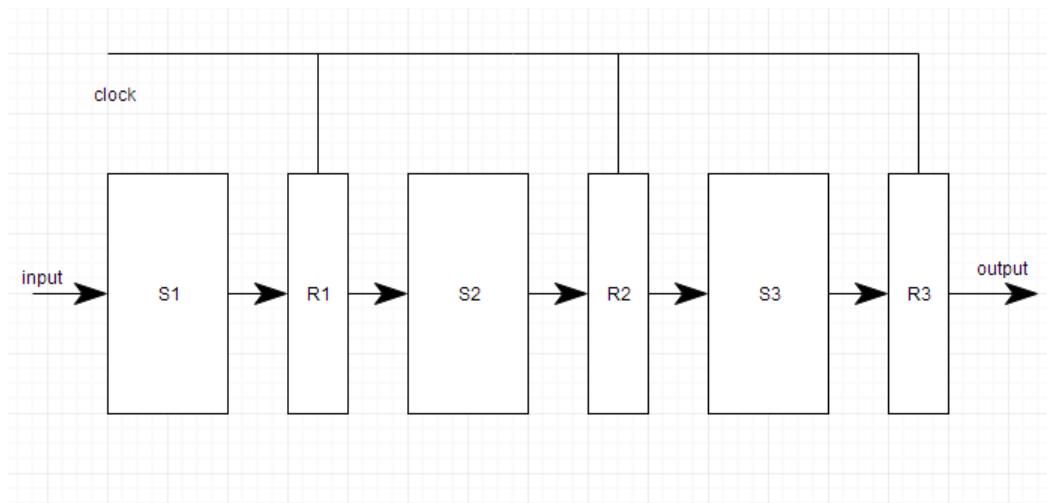

Pipeline system is like the modern day assembly line setup in factories. For example in a car manufacturing industry, huge assembly lines are setup and at each point, there are robotic arms to perform a certain task, and then the car moves on ahead to the next arm.

### Types of Pipeline

It is divided into 2 categories:

1. Arithmetic Pipeline
2. Instruction Pipeline

### Arithmetic Pipeline

Arithmetic pipelines are usually found in most of the computers. They are used for floating point operations, multiplication of fixed point numbers etc. For example: The input to the Floating Point Adder pipeline is:

$$X = A * 2^a$$

$$Y = B * 2^b$$

Here A and B are mantissas (significant digit of floating point numbers), while **a** and **b** are exponents.

The floating point addition and subtraction is done in 4 parts:

1. Compare the exponents.
2. Align the mantissas.
3. Add or subtract mantissas
4. Produce the result.

Registers are used for storing the intermediate results between the above operations.

## Instruction Pipeline

In this a stream of instructions can be executed by overlapping *fetch*, *decode* and *execute* phases of an instruction cycle. This type of technique is used to increase the throughput of the computer system.

An instruction pipeline reads instruction from the memory while previous instructions are being executed in other segments of the pipeline. Thus we can execute multiple instructions simultaneously. The pipeline will be more efficient if the instruction cycle is divided into segments of equal duration.

### Advantages of Pipelining

1. The cycle time of the processor is reduced.
2. It increases the throughput of the system
3. It makes the system reliable.

---

### Disadvantages of Pipelining

1. The design of pipelined processor is complex and costly to manufacture.
2. The instruction latency is more.

## Vector(Array) Processing

There is a class of computational problems that are beyond the capabilities of a conventional computer. These problems require vast number of computations on multiple data items, that will take a conventional computer(with scalar processor) days or even weeks to complete.

Such complex instructions, which operates on multiple data at the same time, requires a better way of instruction execution, which was achieved by Vector processors.

Scalar CPUs can manipulate one or two data items at a time, which is not very efficient. Also, simple instructions like **ADD A to B, and store into C** are not practically efficient.

Addresses are used to point to the memory location where the data to be operated will be found, which leads to added overhead of data lookup. So until the data is found, the CPU would be sitting ideal, which is a big performance issue.

Hence, the concept of **Instruction Pipeline** comes into picture, in which the instruction passes through several sub-units in turn. These sub-units perform various independent functions, **for example**: the **first** one decodes the instruction, the **second** sub-unit fetches the data and the **third** sub-unit performs the math itself. Therefore, while the data is fetched for one instruction, CPU does not sit idle, it rather works on decoding the next instruction set, ending up working like an assembly line.

Vector processor, not only use Instruction pipeline, but it also pipelines the data, working on multiple data at the same time.

A normal scalar processor instruction would be **ADD A, B**, which leads to addition of two operands, but what if we can instruct the processor to **ADD** a group of numbers(from **0** to **n** memory location) to another group of numbers(lets say, **n** to **k** memory location). This can be achieved by vector processors.

In vector processor a single instruction, can ask for multiple data operations, which saves time, as instruction is decoded once, and then it keeps on operating on different data items.

**Applications of Vector Processors**

Computer with vector processing capabilities are in demand in specialized applications. The following are some areas where vector processing is used:

1. Petroleum exploration.
2. Medical diagnosis.
3. Data analysis.
4. Weather forecasting.
5. Aerodynamics and space flight simulations.
6. Image processing.
7. Artificial intelligence.